

LD400 series

HART® & 4 to 20 mA and *WirelessHART™*

PRESSURE TRANSMITTERS

FOR PRESSURE, LEVEL AND FLOW APPLICATIONS



- $\pm 0.045\%$ Accuracy
- $\pm 0.2\%$ of URL Stability Guarantee For 12 Years
- 200:1 Rangeability
- 35 ms Total Response Time
- Non-volatile Flow Totalizer (not available for *WirelessHART™*)
- Tank Linearization
- PID Control Capability (not available for *WirelessHART™*)
- Advanced Diagnostics
- Bi-directional Flow Measurement
- Supports DD, EDDL, and FDT/DTM
- Non-polarity Power Input
- Built-in Transient Suppression
- SIL 2 - Safety Certified to IEC 61508 by TÜV



www.contromat.com

✉ info@contromat.com | ☎ +972-3-9744044



HART
COMMUNICATION PROTOCOL



WirelessHART

smar

- Low Total Probable Error (TPE);
- User-friendly rotative display;
- Local Span/Zero calibration and easy on-site configuration;
- Easy installation, quick commissioning and setup;
- Online continuous sensor and electronic diagnostics reduce troubleshooting time and eliminate unnecessary trips to the field;
- Modularity for all models;
- Persistent Flow Totalizer (not available for *WirelessHART™*);
- Transfer functions: linear, linearization table, \sqrt{x} , $\sqrt{x^3}$, $\sqrt{x^5}$;
- Configurable user unit;
- Span as small as 50 Pa (0.2 inH₂O) up to a range limit of 40 MPa (5800 psi);
- Up to 32 MPa static pressure (4600 psi);
- 10,000 psi Burst Pressure Limit;
- Easy specification simplifying customers' Total Cost of Ownership (TCO);

HART®

- Output current with 0.75 μ A resolution;
- Output Limits according to NAMUR NE43;
- Software Management according to NAMUR NE53;
- Direct digital capacitance sensing (No A/D conversion);
- Based on technology proven in use since the early '80s;
- HART® configurable;
- Built-in surge protection;
- Fully selectable constant mA output (Loop Test capability);
- Single electronics board covers complete range;
- It is certified to IEC61508 for SIL 1 and SIL 2 (non-redundant) and SIL 3 (redundant) applications.

WirelessHART™

- Repeaters/Routers function in the mesh network;
- "Burst Mode" for periodical sending of commands;
- Powered by long life battery (up to 5 years);
- HART® 7 / *WirelessHART™* protocol;
- Status diagnostics;
- Distance up to 250 m from other network equipment;
- Configuration by magnetic tool (local adjustment), HPC401, CONF401, DDCON100, FDT/DTM and DD tools;
- Mesh, Star and combination of both network topology;
- Hardware and software write protection;
- Wireless standard IEEE 802.15.4-2006 @ 250 kbps;
- Frequency band 2.4 GHz.

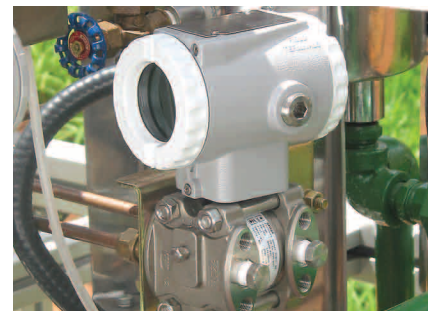
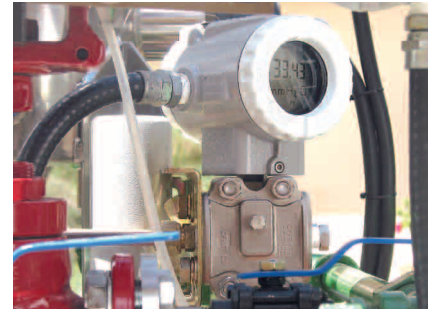
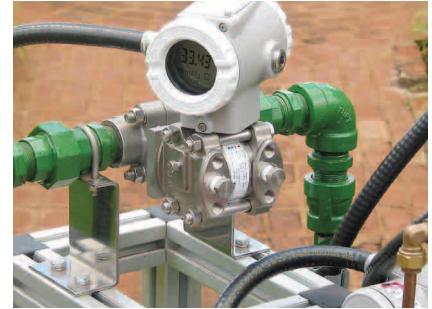

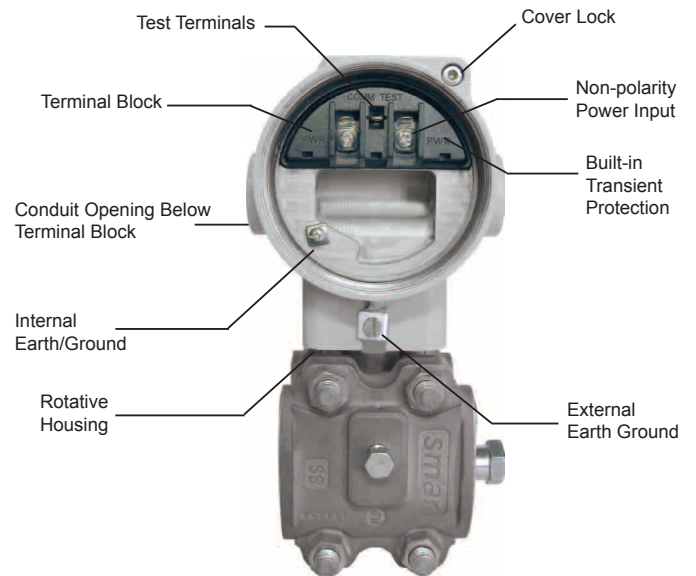
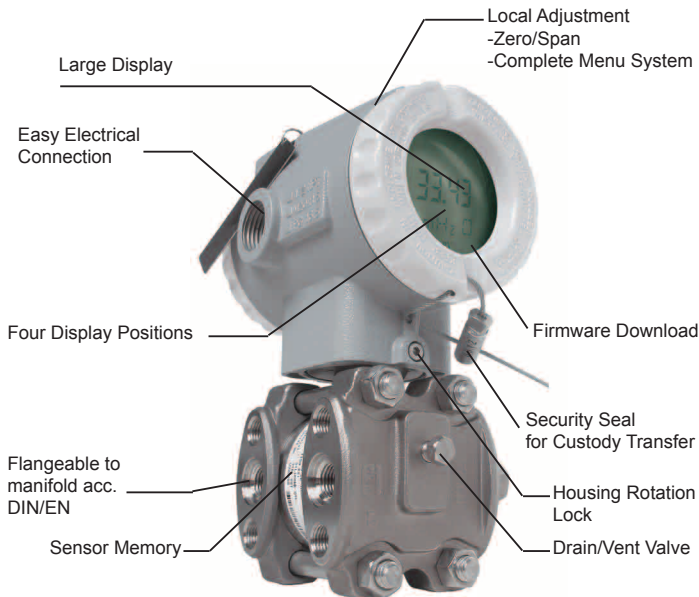

LD400 HART® Functional Description

LD400 consists of differential, absolute and gauge pressure transmitters as well as models for both level and remote seal applications. The **LD400** offers the best solution for all field applications and those demanding the highest performance.

LD400 offers:

- ± 0.045% accuracy for High Performance option;
- ± 0.2 % of URL stability guarantee for 12 years;
- 200:1 rangeability;
- Compactness and lightweight;
- Safe and reliable operation.

LD400 uses the field-proven technique of capacitance cell sensor measurement.

The sensor is shown in the picture on side. The sensing diaphragm (1) is at the cell center. The diaphragm deflects as a result of the difference between the pressures applied to the left and right sides of the sensor (PH and PL). Pressure is directly applied to the isolating diaphragms (2), which provide resistance against process fluid corrosion. The pressure is transmitted to the sensing diaphragm through the filling fluid (3).

The sensing diaphragm is a moving capacitor plate while the two metallized surfaces (4) are fixed plates. The sensing diaphragm deflection results in capacitance variations between the moving and fixed plates.

The electronic resonance circuit reads capacitance variation between the moving and fixed plates. The CPU conditions the measurement and communicates according to protocol. As there is no A/D conversion, errors and drifts during conversions are eliminated. A temperature

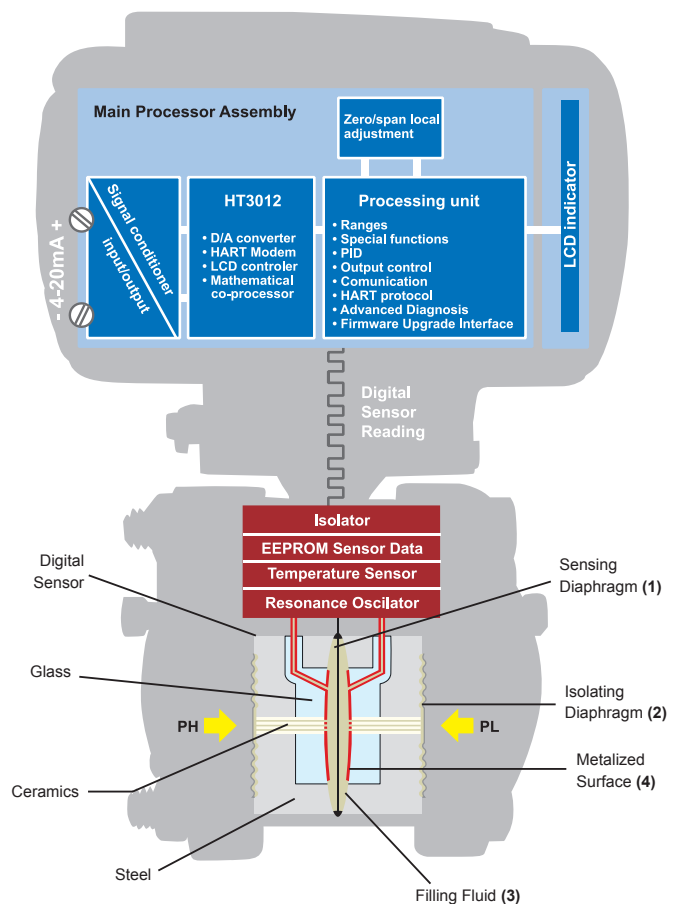

sensor provides temperature compensations, which combined with the sensor precision, results in high accuracy and rangeability for the **LD400**.

The process variable, as well as monitoring and diagnostics information, is provided by digital communication protocol.

Smarter **LD400** is designed to be rugged and a highly reliable solution in pressure measurement. It delivers great application flexibility using the direct digital capacitance sensing that keeps the signal digital all the way from sensor to the output, resulting in a higher

effective resolution. All the processing is made by HT3012, the powerful mathematical co-processor that ensure fast response time and high performance for the transmitter. **LD400** is the best choice for pressure measurement.

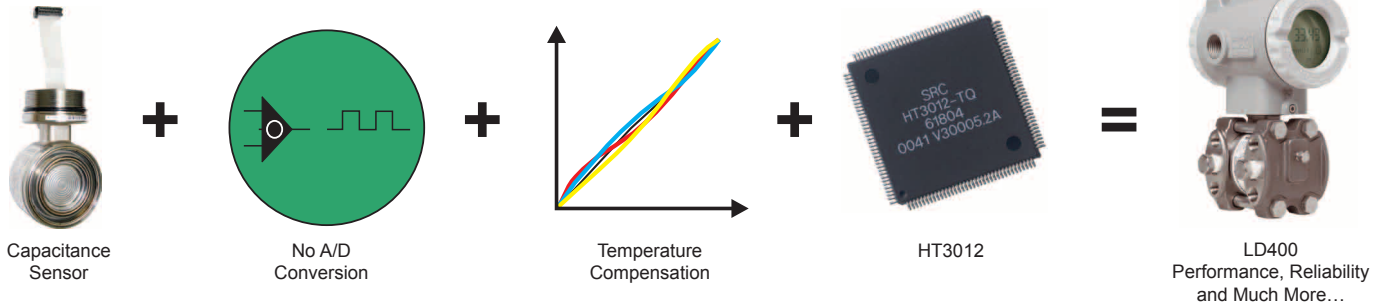

LD400 *WirelessHART*™ Functional Description

WirelessHART™ Technology

The world dedicated HART® technology now offers a robust protocol designed for numerous applications, with the advantage of the wireless feature. Economy installation and efficient management of energy, quick access to information from the field, strength in communication and information integrity, network security: this and so many other advantages that make *WirelessHART*™ technology (more on www.hartcomm.org) who came to the world of automation to innovate and revolutionize.

Based on a communication protocol for wireless mesh network, the *WirelessHART*™ protocol ensures compatibility between instruments, commands and existing HART® tools. Basically, a *WirelessHART*™ network is composed of elements like the figure beside.

The picture elements in the network, constitute the so-called mesh network. They are:

- Host - workstation that allows interaction with the process. Through the *WirelessHART*™ Gateway, the host gathers data from instruments connected to the network in question. Uses protocols such as Profibus, High Speed Ethernet (HSE), among others;
- *WirelessHART*™ Gateway - converts data between host and devices connected to the network. Together with wireless transmitters Smar, uses the DF100 Gateway. It incorporates the features of Network Manager and Access Point.
- Network Manager - distributes, among other responsibilities, the identity of the network, publishing its existence; distributes individual security keys to the instruments; assigns a communication band to them; manages the communication routes between them, etc.. It is an application that can be incorporated into the *WirelessHART*™ Gateway.
- Access Point - in a simple way, can be understood as the radio installed in *WirelessHART*™ Gateway.

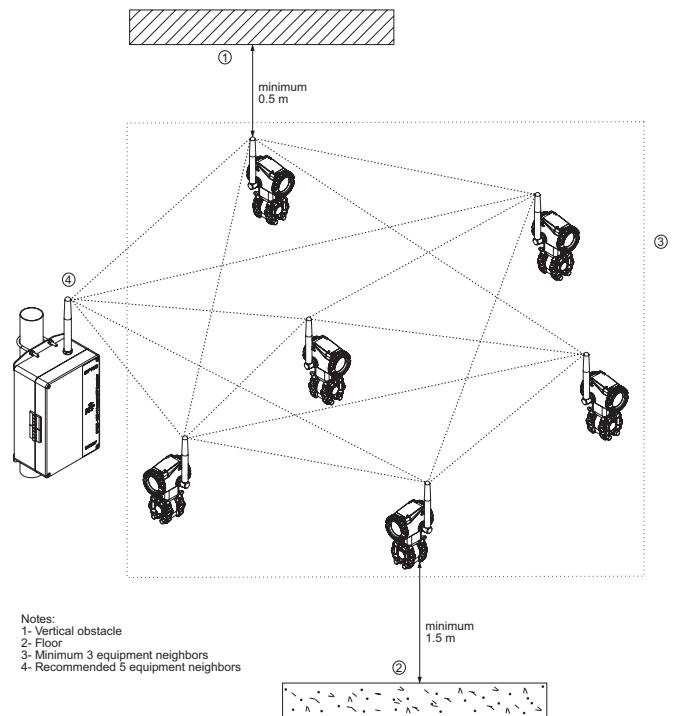

- *WirelessHART*™ field devices - the DT400, TT400 and LD400 are Smarter *WirelessHART*™ field devices for this type of network. They act, in addition to its functionality as transmitters, such as routers (repeaters), being able to relay messages to / from other instruments on the network.
- *WirelessHART*™ Adapter - is a tool "bridge", capable of delivering data from a field instrument 4-20 mA HART® (wired) to the host via *WirelessHART*™, then allowing that a conventional HART field device be part of a *WirelessHART*™ network.

The *WirelessHART*™ instruments should be field installed and configured the same way as conventional HART® instruments. This is possible with the DD (device Description) files updated and uploaded to your Hart configurator, that can be used normally. The *WirelessHART*™ instruments can be either configured previously in bench or at the time of installation.

Differential Pressure - LD400D and LD400H

Pressure is applied to high and low side and differential pressure is measured. High static pressure is supported for **LD400H** models.

Flow - LD400D and LD400H

The differential pressure is generated by a primary flow element and the square root function computes the flow measurement.

Gage Pressure - LD400M and LD400G

The pressure is measured at the high side of the transmitter and the low side is open to the atmosphere, providing true local atmospheric reference.

Absolute Pressure - LD400A

The pressure is measured at the high side of the transmitter and the low side is at zero absolute pressure to a sealed chamber with vacuum.

Level - LD400L and LD400I

The transmitter has a flange-mounted unit for direct installation on vessels. Extended diaphragms are also available. The closed tank low side can compensate for ullage pressure.

Sanitary - LD400S

LD400S is especially designed for food and other applications where sanitary connections are required. With threaded or "tri-clamp" connections, it allows quick and easy cleaning and maintenance. The flush connection enables deposit removal without disconnecting the seal. Tri-clamp and other connections are compliant to 3A-7403 standard for food grade applications. For further information, see the Smar SR301 Series Catalog.



Remote Seals

SR301 is a remote seal designed for chemical and thermal isolation. **LD400** can be assembled with separate diaphragm seals in either one or both sides of the sensor. SR301 options include: "T" Type Flanged (SR301T), Threaded (SR301R), Pancake (SR301P) where those three models with an optional flush connection, Sanitary (SR301S), Flanged with Extension (SR301E) and Pancake with Extension (SR301Q).

Typical applications for **LD400** with remote seals:

- Corrosive process fluid;
- Suspended solids or viscous process fluid;
- Process fluids that may freeze or solidify;
- Process temperatures higher than supported by transmitters;
- Replaces impulse lines and condensate legs;
- Bubble system.

See the SR301 Series Catalog for further information regarding application and specification.

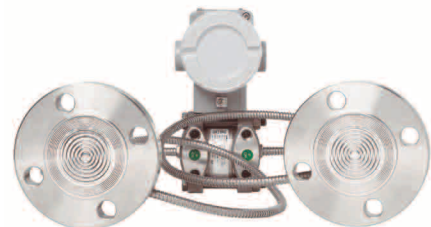

Manifold Valves

Smar manifold valves provide all of the necessary safety for field maintenance of **LD400** transmitters. Working at pressures of up to 6,000 psi, they are easy to handle and lighter than others in the market. Pressure and leakage tests are present in 100% of the valves, also for models mounted on the transmitter. For further information, please see the Smar Manifold Valves Catalog.



Parameterization and Diagnostics

The **LD400 SIS** is certified by TÜV and meets IEC 61508 standard recommendations for SIS (Safety Instrumented Systems) applications. For more informations about SIS, please consult the **LD400** Operation and Maintenance Instruction Manual.

LD400 HART SIS is certified by TUV and meet the recommendations IEC 61508 standard for SIS (Safety Instrumented Systems) applications. For more information about SIS, please consult LD400 Operations, Maintenance and Instructions Manual.

Note:

LD400 HART® SIS has the housing cover in red to distinguish them from the standard model.

Parameterization and Diagnostics

LD400 is available in HART® technology. These instruments can be configured with Smar software and other manufacturer configuration tools. Local adjustment is available in all **LD400**. It is possible to configure zero and span, totalization, setpoint and other control functions using the magnetic screwdriver.

Smar has developed AssetView, which is a user-friendly Web Tool that can be accessed anywhere and anytime using an internet browser. It is designed for management and diagnostics of field devices, to ensure reactive, preventive, predictive and proactive maintenance.



LD400 with HART® protocol can be configured by:

- Smar CONF401 for Windows;
- Smar DDCON 100 for Windows;
- Smar HPC401 for most recent models of Palms;
- Other manufacturers' configuration tools based on DD (Device Description), Simatic PDM, and FDT/DTM, such as AMSTM, FieldCare™, PACTware™, HHT275 and HHT375, PRM Device Viewer.

For **LD400** management and diagnostics, AssetView ensures continuous information monitoring.



Universal HART® Configuration Software



HPC401

Advanced Diagnostics

Smar **LD400** provides diagnostics on several levels allowing quick maintenance and in a safe way:

- Sensor Level
- Electronics Level
- Loop integrity Level

The **LD400** performs advanced diagnostics upon powering up the instrument. It verifies the integrity of important data in order for the device to work properly: the characterization data, the customer entered data, the calibration data and the RAM memory.

During the operation, the validity of the measured pressure is continuously checked. Using advanced algorithms, the transmitter can identify when there is a failure and if it is

due to a hardware failure or a process overload condition. It also checks over and under temperature conditions. The user can configure the safe condition according to NAMUR NE43. When the result is failure it can cause an incorrect output, the transmitter will immediately switch the output current allowing actions by the user to identify and correct the problem.

The **LD400 SIS** model not only includes all the previously mentioned diagnostics but also some extra ones to reach the required safety level. They are:

- 4-20 mA Current Output Monitoring;
- Memory and CPU Integrity Checking;
- Crystal Monitoring;
- Firmware Execution Sequence Monitoring.

HART®

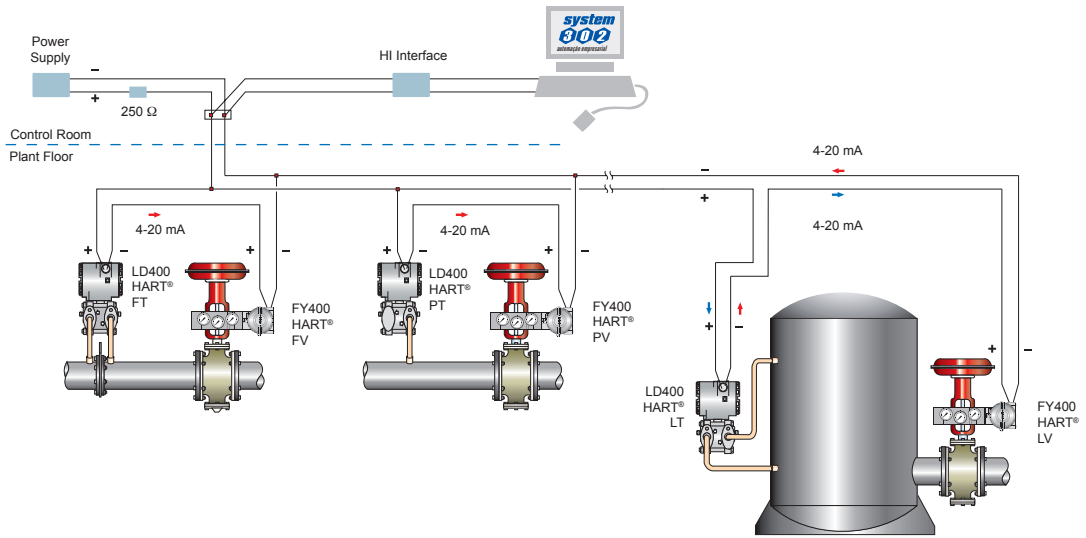

WirelessHART™

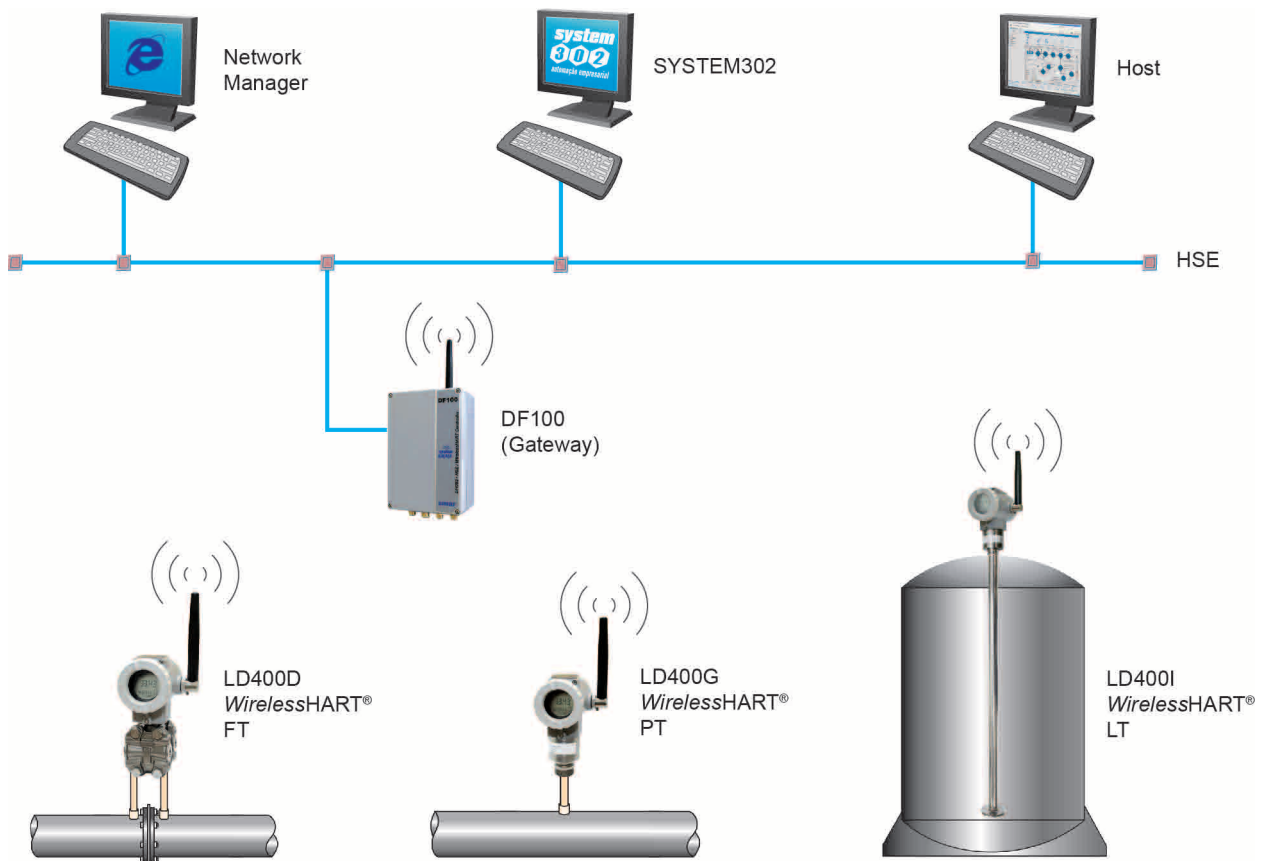

Functional Specifications

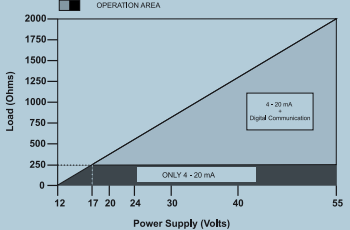
<p>Process Fluid</p>	<p>Liquid, gas or steam.</p>
<p>Output and Communication Protocol</p>	<p>HART®: Two-wire, 4-20 mA controlled according to NAMUR NE43 specification, with super-imposed digital HART® Protocol.</p> <p>WirelessHART™: HART® Version 7 protocol, with LD400 <i>WirelessHART™</i> command set.</p> <p>A HART® transmitter specific review must be managed according to the LD400 <i>WirelessHART™</i> transmitter.</p>
<p>Power Supply</p>	<p>HART®: 12 to 55 Vdc. Input without polarization, with protection for transient suppressor and complemented by a Lightning Arrester.</p> <p>Transient Suppressor: Vmax = 65 Vp; Differential Mode - bi-directional; Low current leak and capacitance; Meets the standards: IEEE61000-4-4 and IEEE61000-4-5; Less than 5 ns response time.</p> <p>Lightning Arrester: V = 1000 Vdc; Discharge current peak = 10 kA; Nominal current = 10 A for 1 s; Common mode - low leak current and capacitance</p> <p>WirelessHART™: The battery pack consists of two primary lithium batteries of 3.6 V, totaling 7.2 V.</p> <p>Battery duration: - Update every 8s: 4 years.</p>
<p>Indicator</p>	<p>Rotative LCD, with 4½-numerical digit and 5-character alphanumerical. Function and status icons.</p>
<p>Hazardous Area Certifications</p>	<p>HART®: Explosion Proof, intrinsically safe and increased safety (CEPEL)</p> <p>WirelessHART™: Explosion proof and intrinsic safe (pending)</p>
<p>Zero and Span Adjustments</p>	<p>HART®: Non-interactive, via local adjustment and digital communication. Local adjustment jumper with 3 positions: Simple, Disabled and Complete.</p> <p>WirelessHART™: Jumper of local adjustment with two positions: Able and Disable.</p>
<p>Load Limitation</p>	<p>The equation to determine the maximum load resistance this described below: Maximum Load Resistance = [46.07*(Supply Voltage - 10.5)] Ohms</p> 
<p>Failure Alarm (Diagnostics)</p>	<p>HART®: Detailed diagnostics through communication. Sensor failure indication and overpressure indication. In case of sensor or circuit failure, the self-diagnostics drives the output to 3.6 or 21.0 mA, according to the user's choice and NAMUR NE43 specification.</p> <p>WirelessHART™: Detailed diagnostics via HART® communicator and via the display. Indication of sensor failure and overpressure.</p>

Temperature Limits	Ambient: -40 to 85 °C (-40 to 185 °F) Process: -40 to 100 °C (-40 to 212 °F) (Silicone Oil) -40 to 85 °C (-40 to 185 °F) (Inert Halocarbon Oil) 0 to 85 °C (32 to 185 °F) (Fluorolube Oil) -20 to 85 °C (-4 to 185 °F) (Inert Krytox Oil and Fomblim Oil) -25 to 100 °C (-13 to 212 °F) (Viton O'Ring) -40 to 150 °C (-40 to 302 °F) (Level Model) Storage: -40 to 100 °C (-40 to 212 °F) Digital Display: -20 to 80 °C (-4 to 176 °F) -40 to 85 °C (-40 to 185 °F) (Withou Damage)																																																																																
Configuration	By digital communication using the configuration software CONF401, DDCON 100 (for Windows) or HPC401 (for Palms), and can be partially configured through local adjustment. LD400 and LD400 WirelessHART™ can be configured using third-party configuration tools. Firmware downloading via BDM. Writing-protection jumper.																																																																																
Overpressure and Static Pressure Limits (MWP–Maximum Working Pressure)	From 3.45 kPa abs. (0.5 psia) to: 0.5 MPa (72.52 psi) for range 0 8 MPa (1150 psi) for range 1 16 MPa (2300 psi) for range 2, 3 e 4 32 MPa (4600 psi) for models H e A5 40 MPa (5800 psi) for model M5 52 MPa (7500 psi) for models M6 e A6 Flange Test Pressure: 68.95 MPa (10000 psi) Overpressures above will not damage the transmitter, but a new calibration may be necessary. <div style="border: 1px solid black; padding: 5px; text-align: center;"> <p>WARNING</p> <p>It is described here only the maximum pressures of the materials referenced in each rule, it can not be manufactured on request.</p> <p>Temperatures above 150 °C are not available in standard models.</p> </div> <p style="text-align: center;">PRESSURES TABLE FOR SEAL AND LEVEL FLANGES DIN EN 1092-1 2008 STANDARD</p> <table border="1" style="width: 100%; border-collapse: collapse;"> <thead> <tr> <th rowspan="3">Material Group</th> <th rowspan="3">Pressure Class</th> <th colspan="7">Maximum Temperature Allowed</th> </tr> <tr> <th>RT</th> <th>100</th> <th>150</th> <th>200</th> <th>250</th> <th>300</th> <th>350</th> </tr> <tr> <th colspan="7">Maximum Pressure Allowed (bar)</th> </tr> </thead> <tbody> <tr> <td rowspan="7">10E0 AISI 304/304L</td> <td>PN 16</td> <td>16</td> <td>13.7</td> <td>12.3</td> <td>11.2</td> <td>10.4</td> <td>9,6</td> <td>9.2</td> </tr> <tr> <td>PN 25</td> <td>25</td> <td>21.5</td> <td>19.2</td> <td>17.5</td> <td>16.3</td> <td>15.1</td> <td>14.4</td> </tr> <tr> <td>PN 40</td> <td>40</td> <td>34.4</td> <td>30.8</td> <td>28</td> <td>26</td> <td>24.1</td> <td>23</td> </tr> <tr> <td>PN 63</td> <td>63</td> <td>63</td> <td>57.3</td> <td>53.1</td> <td>50.1</td> <td>46.8</td> <td>45</td> </tr> <tr> <td>PN 100</td> <td>100</td> <td>86.1</td> <td>77.1</td> <td>70</td> <td>65.2</td> <td>60.4</td> <td>57.6</td> </tr> <tr> <td>PN 160</td> <td>160</td> <td>137.9</td> <td>123.4</td> <td>112</td> <td>104.3</td> <td>96.7</td> <td>92.1</td> </tr> <tr> <td>PN 250</td> <td>250</td> <td>215.4</td> <td>192.8</td> <td>175</td> <td>163</td> <td>151.1</td> <td>144</td> </tr> </tbody> </table>	Material Group	Pressure Class	Maximum Temperature Allowed							RT	100	150	200	250	300	350	Maximum Pressure Allowed (bar)							10E0 AISI 304/304L	PN 16	16	13.7	12.3	11.2	10.4	9,6	9.2	PN 25	25	21.5	19.2	17.5	16.3	15.1	14.4	PN 40	40	34.4	30.8	28	26	24.1	23	PN 63	63	63	57.3	53.1	50.1	46.8	45	PN 100	100	86.1	77.1	70	65.2	60.4	57.6	PN 160	160	137.9	123.4	112	104.3	96.7	92.1	PN 250	250	215.4	192.8	175	163	151.1	144
Material Group	Pressure Class			Maximum Temperature Allowed																																																																													
				RT	100	150	200	250	300	350																																																																							
		Maximum Pressure Allowed (bar)																																																																															
10E0 AISI 304/304L	PN 16	16	13.7	12.3	11.2	10.4	9,6	9.2																																																																									
	PN 25	25	21.5	19.2	17.5	16.3	15.1	14.4																																																																									
	PN 40	40	34.4	30.8	28	26	24.1	23																																																																									
	PN 63	63	63	57.3	53.1	50.1	46.8	45																																																																									
	PN 100	100	86.1	77.1	70	65.2	60.4	57.6																																																																									
	PN 160	160	137.9	123.4	112	104.3	96.7	92.1																																																																									
	PN 250	250	215.4	192.8	175	163	151.1	144																																																																									

Overpressure and Static Pressure Limits (MWP– Maximum Working Pressure) (continuation)

Material Group	Pressure Class	Maximum Temperature Allowed						
		RT	100	150	200	250	300	350
		Maximum Pressure Allowed (bar)						
14E0 AISI 316/316L	PN 16	16	16	14.5	13.4	12.7	11.8	11.4
	PN 25	25	25	22.7	21	19.8	18.5	17.8
	PN 40	40	40	36.3	33.7	31.8	29.7	28.5
	PN 63	63	63	57.3	53.1	50.1	46.8	45
	PN 100	100	100	90.9	84.2	79.5	74.2	71.4
	PN 160	160	160	145.5	134.8	127.2	118.8	114.2
	PN 250	250	250	227.3	210.7	198.8	185.7	178.5

Material Group	Pressure Class	Maximum Temperature Allowed						
		RT	100	150	200	250	300	350
		Maximum Pressure Allowed (bar)						
16E0 1.4410 Super Duplex 1.4462 Duplex	PN 16	16	16	16	16	16	-	-
	PN 25	25	25	25	25	25	-	-
	PN 40	40	40	40	40	40	-	-
	PN 63	63	63	63	63	63	-	-
	PN 100	100	100	100	100	100	-	-
	PN 160	160	160	160	160	160	-	-
	PN 250	250	250	250	250	250	-	-

PRESSURES TABLE FOR SEAL AND LEVEL FLANGES ASME B16.5 2009 STANDARD

Material Group	Pressure Class	Maximum Temperature Allowed								
		-29 to 38	50	100	150	200	250	300	325	350
		Maximum Pressure Allowed (bar)								
Hastelloy C276	150	20	19.5	17.7	15.8	13.8	12.1	10.2	9.3	8.4
	300	51.7	51.7	51.5	50.3	48.3	46.3	42.9	41.4	40.3
	400	68.9	68.9	68.7	66.8	64.5	61.7	57	55	53.6
	600	103.4	103.4	103	100.3	96.7	92.7	85.7	82.6	80.4
	900	155.1	155.1	154.6	150.6	145	139	128.6	124	120.7
	1500	258.6	258.6	257.6	250.8	241.7	231.8	214.4	206.6	201.1
	2500	430.9	430.9	429.4	418.2	402.8	386.2	357.1	344.3	335.3

Material Group	Pressure Class	Maximum Temperature Allowed								
		-29 to 38	50	100	150	200	250	300	325	350
		Maximum Pressure Allowed (bar)								
S31803 Duplex S32750 Super Duplex	150	20	19.5	17.7	15.8	13.8	12.1	10.2	9.3	8.4
	300	51.7	51.7	50.7	45.9	42.7	40.5	38.9	38.2	37.6
	400	68.9	68.9	67.5	61.2	56.9	53.9	51.8	50.9	50.2
	600	103.4	103.4	101.3	91.9	85.3	80.9	77.7	76.3	75.3
	900	155.1	155.1	152	137.8	128	121.4	116.6	114.5	112.9
	1500	258.6	258.6	253.3	229.6	213.3	202.3	194.3	190.8	188.2
	2500	430.9	430.9	422.2	382.7	355.4	337.2	323.8	318	313.7

Overpressure and Static Pressure Limits (MWP–Maximum Working Pressure) (continuation)	Material Group	Pressure Class	Maximum Temperature Allowed								
			-29 to 38	50	100	150	200	250	300	325	350
	Material Group	Pressure Class	Maximum Pressure Allowed (bar)								
			150	15.3	13.3	12	11.2	10.5	10	9.3	8.4
	AISI316L	300	41.4	40	34.8	31.4	29.2	27.5	26.1	25.5	25.1
		400	55.2	53.4	46.4	41.9	38.9	36.6	34.8	34	33.4
		600	82.7	80	69.6	62.8	58.3	54.9	52.1	51	50.1
		900	124.1	120.1	104.4	94.2	87.5	82.4	78.2	76.4	75.2
		1500	206.8	200.1	173.9	157	145.8	137.3	130.3	127.4	125.4
		2500	344.7	333.5	289.9	261.6	243	228.9	217.2	212.3	208.9
		Material Group	Pressure Class	Maximum Temperature Allowed							
	Material Group	Pressure Class	Maximum Pressure Allowed (bar)								
			150	19	18.4	16.2	14.8	13.7	12.1	10.2	9.3
	AISI316	300	49.6	48.1	42.2	38.5	35.7	33.4	31.6	30.9	30.3
		400	66.2	64.2	56.3	51.3	47.6	44.5	42.2	41.2	40.4
		600	99.3	96.2	84.4	77	71.3	66.8	63.2	61.8	60.7
		900	148.9	144.3	126.6	115.5	107	100.1	94.9	92.7	91
		1500	248.2	240.6	211	192.5	178.3	166.9	158.1	154.4	151.6
		2500	413.7	400.9	351.6	320.8	297.2	278.1	263.5	257.4	252.7
		Material Group	Pressure Class	Maximum Temperature Allowed							
	Material Group	Pressure Class	Maximum Pressure Allowed (bar)								
			150	19	18.3	15.7	14.2	13.2	12.1	10.2	9.3
	AISI304	300	49.6	47.8	40.9	37	34.5	32.5	30.9	30.2	29.6
600		99.3	95.6	81.7	74	69	65	61.8	60.4	59.3	
1500		248.2	239.1	204.3	185	172.4	162.4	154.6	151.1	148.1	
2500		413.7	398.5	340.4	308.4	287.3	270.7	257.6	251.9	246.9	
Turn-on Time		<p>HART®: Performs within specifications in less than 3 seconds after power is applied to the transmitter.</p> <p>WirelessHART™: Performs within specifications in less than 10 seconds after power is applied to the transmitter.</p>									
Humidity Limits	0 to 100% RH (Relative Humidity).										
Volumetric Displacement	Less than 0.15 cm ³ (0.01 in ³).										
Damping Adjustment	User configurable from 0 to 128 seconds (via digital communication or local adjustment).										

Performance Specifications

Reference Conditions	Span starting at zero, temperature of 25 °C (77 °F), atmospheric pressure, power supply of 24 Vdc, Halocarbon or Silicone oil fill fluid, isolating diaphragms in 316L SST and digital trim equal to lower and upper range values.
Stability	<p>For ranges 2, 3, 4, 5 or 6: High Performance: ± 0.2% of URL for 12 years Standard: ± 0.15% of URL for 7 years For ± 20 °C temperature changes, 0-100% relative humidity, up to 7 MPa (70 bar) line pressure, installation according to the best practices and adequate assembling for processes in which atoms of hydrogen can be generated (hydrogen migration).</p> <p>For range 1: High Performance: ± 0.3% of URL for 12 years Standard: ± 0.3% of URL for 7 years For ± 20 °C temperature changes, 0-100% relative humidity, up to 3.5 kPa (35 mbar) line pressure, installation according to the best practices and adequate assembling for processes in which atoms of hydrogen can be generated (hydrogen migration).</p> <p>For range 0: High Performance: ± 0.4% of URL for 12 years Standard: ± 0.4% of URL for 7 years For ± 20 °C temperature changes, 0-100% relative humidity, up to 100 kPa (1 bar) line pressure, installation according to the best practices and adequate assembling for processes in which atoms of hydrogen can be generated (hydrogen migration).</p>
Accuracy	<p>STANDARD:</p> <p>Ranges D0 or M0: 0.16 URL ≤ span ≤ URL: ± 0.1 % of span 0.05 URL ≤ span < 0.16 URL: ± [0.0545 + 0.0073 URL/span] % of span</p> <p>Ranges D1 or M1: 0.16 URL span URL: ± 0.06% of span 0.025 URL span < 0.16 URL: ± [0.0364 + 0.0038 URL/span] % of span</p> <p>Ranges D2, D3, D4, M2, M3, M4, H2, H3 or H4: 0.16 URL span URL: ± 0.06% of span 0.025 URL span < 0.16 URL: ± [0.0364 + 0.0038 URL/span] % of span 0.005 URL span < 0.025 URL: ± [0.0015 + 0.0047 URL/span] % of span</p> <p>Ranges M5, H5, S2, S3, S4 or S5: 0.16 URL span URL: ± 0.065 % of span 0.025 URL span < 0.16 URL: ± [0.0326 + 0.0052 URL/span] % of span 0.0083 URL span < 0.025 URL: ± [0.01 + 0.0058 URL/span] % of span</p> <p>Range M6: 0.16 URL span URL: ± 0.08 % of span 0.025 URL span < 0.16 URL: ± [0.0504 + 0.0047 URL/span] % of span 0.0083 URL span < 0.025 URL: ± [0.005 + 0.0059 URL/span] % of span</p> <p>Range A0: 0.16 URL span URL: ± 0.2 % do span 0.05 URL span 0.16 URL: ± (0.158 + 0,006 URL/span) % do span</p> <p>Range A1: 0.16 URL span URL: ± 0.1 % do span 0.05 URL span < 0.16 URL: ± [0.065 + 0,0054 URL/span] % do span</p> <p>Range A2: 0.16 URL span URL: ± 0.08 % of span 0.05 URL span < 0.16 URL: ± [0.0482 + 0.0051 URL/span] % of span</p>

<p>Accuracy (continuation)</p>	<p>Ranges A3 or A4: 0.16 URL span URL: ± 0.065 % of span 0.025 URL span < 0.16 URL: $\pm [0.0326 + 0.0052 \text{ URL/span}]$ % of span 0.0083 URL span < 0.025 URL: $\pm [0.005 + 0.0059 \text{ URL/span}]$ % of span</p> <p>Range A5: 0.16 URL span URL: ± 0.075 % of span 0.025 URL span < 0.16 URL: $\pm [0.0443 + 0.0049 \text{ URL/span}]$ % of span 0.0083 URL span < 0.025 URL: $\pm [0.001 + 0.006 \text{ URL/span}]$ % of span</p> <p>Ranges A6, L2, L3, L4 or L5: 0.16 URL span URL: ± 0.08 % of span 0.025 URL span < 0.16 URL: $\pm [0.0504 + 0.0047 \text{ URL/span}]$ % of span 0.0083 URL span < 0.025 URL: $\pm [0.005 + 0.0059 \text{ URL/span}]$ % of span</p> <p>HIGH PERFORMANCE:</p> <p>Ranges D0 or M0: 0.16 URL span URL: $\pm 0.06\%$ of span 0.05 URL span < 0.16 URL: $\pm [0.0009 + 0.0095 \text{ URL/span}]$ % of span</p> <p>Range D1 or M1: 0.16 URL span URL: ± 0.05 % of span 0.025 URL span < 0.16 URL: $\pm [0.0262 + 0.0038 \text{ URL/span}]$ % of span</p> <p>Ranges D2, D3, D4, M2, M3 or M4: 0.16 URL span URL: ± 0.045 % of span 0.025 URL span < 0.16 URL: $\pm [0.0209 + 0.0039 \text{ URL/span}]$ % of span 0.005 URL span < 0.025 URL: $\pm [0.0025 + 0.0043 \text{ URL/span}]$ % of span</p> <p>Range M5: 0.16 URL span URL: ± 0.055 % of span 0.025 URL span < 0.16 URL: $\pm [0.0263 + 0.0046 \text{ URL/span}]$ % of span 0.0083 URL span < 0.025 URL: $\pm [0.015 + 0.0049 \text{ URL/span}]$ % of span</p> <p>Range M6: 0.16 URL span URL: ± 0.075 % of span 0.025 URL span < 0.16 URL: $\pm [0.0463 + 0.0046 \text{ URL/span}]$ % of span 0.0083 URL span < 0.025 URL: $\pm [0.005 + 0.0056 \text{ URL/span}]$ % of span</p> <p><i>Note: For SIS devices, please consider the standard model specifications.</i></p>
<p>Power Supply Effect</p>	<p>$\pm 0.005\%$ of calibrated span per Volt.</p>
<p>Vibration Effect</p>	<p>$\pm 0.1\%$ URL for field with high vibration level or pipeline with high vibration, according to IEC 60770-1 specification: 10-60 Hz, 0.21 mm peak displacement / 60-2000 Hz, 29.4 m/s² acceleration amplitude.</p>
<p>Temperature Effect</p>	<p>For ranges 2, 3, 4, 5 or 6, except level and sanitary transmitters: 0.1 URL span URL: $\pm [0.0205\% \text{ URL} + 0.0795\% \text{ span}]$ per 20 °C (68 °F) span < 0.1 URL: $\pm [0.021\% \text{ URL} + 0.075\% \text{ span}]$ per 20 °C (68 °F)</p> <p>For range 1: 0.1 URL span URL: $\pm [0.05\% \text{ URL} + 0.08\% \text{ span}]$ per 20 °C (68 °F) span < 0.1 URL: $\pm [0.055\% \text{ URL} + 0.03\% \text{ span}]$ per 20 °C (68 °F)</p> <p>For range 0: 0.1 URL span URL: $\pm [0.1\% \text{ URL} + 0.1\% \text{ span}]$ per 20 °C (68 °F) span < 0.1 URL: $\pm [0.105\% \text{ URL} + 0.05\% \text{ span}]$ per 20 °C (68 °F)</p> <p>For Level or Sanitary Transmitters: 6 mmH₂O per 20 °C for flange 4" and DN100 17 mmH₂O per 20 °C for flange 3" and DN80 Consult for other flange dimensions and fill fluid.</p>

<p>Static Pressure Effect</p>	<p>Zero Error: For range 5*: ± 0.05% URL (± 0.1% for Tantalum diaphragm) per 7 MPa (1000 psi) For range 2, 3 or 4*: ±0.025% URL (± 0.1% for Tantalum diaphragm) per 7 MPa (1000 psi) For range 1: 0.05 % URL per 1.7 MPa (250 psi) For range 0: ± 0.1% URL per 0.5 MPa (5 bar) For Level or Sanitary Transmitters: ± 0.1% URL per 3.5 MPa (500 psi) The zero error is a systematic error that can be eliminated by calibrating at the operating static pressure.</p> <p>Span Error: For ranges 2, 3, 4 or 5*: Correctable to ± 0.1% of reading per 7 MPa (1000 psi) For range 1: Correctable to ± 0.1% of reading per 1.7 MPa (250 psi) For range 0: Correctable to ± 0.2% of reading per 0.5 MPa (5 bar) For Level or Sanitary Transmitters: Correctable to ± 0.1% URL per 3.5 MPa (500 psi)</p> <p>*Except for level or sanitary transmitters</p>		
<p>Mounting Position Effect</p>	<p>Zero shift of up to 250 Pa (1 inH₂O) which can be calibrated out. No span effect.</p>		
<p>Electromagnetic Interference Effect</p>	<p>According to IEC61326-1:2006, IEC61326-2-3:2006, IEC61000-6-4:2006, IEC61000-6-2:2005</p>		
<p>Rangeability</p>	<p>MODEL</p>	<p>RANGEABILITY FOR LD400</p>	<p>RANGEABILITY FOR LD400 SIS</p>
	D0	20:1	10:1
	D1	40:1	10:1
	D2	200:1	20:1
	D3	200:1	20:1
	D4	200:1	20:1
	M0	20:1	10:1
	M1	40:1	10:1
	M2	200:1	20:1
	M3	200:1	20:1
	M4	200:1	20:1
	M5	120:1	20:1
	M6	120:1	20:1
	A0	20:1	-
	A1	20:1	4:1
	A2	20:1	10:1
	A3	120:1	20:1
	A4	120:1	20:1
	A5	120:1	20:1
	A6	120:1	-
	H2	120:1	20:1
	H3	120:1	20:1
	H4	120:1	20:1
	H5	120:1	20:1
	L2	120:1	20:1
	L3	120:1	20:1
	L4	120:1	20:1
	L5	120:1	20:1
	S2	120:1	20:1
	S3	120:1	20:1
	S4	120:1	20:1
	S5	120:1	20:1

Physical Specifications

<p>Electrical Connection</p>	<p>HART® ½ - 14 NPT ¾ - 14 NPT (with 316 SST adapter for ½ - 14 NPT) M20 X 1.5 ¾ - 14 BSP (with 316 SST adapter for ½ - 14 NPT) PG 13.5 DIN ½ - 14 BSP (with 316 SST adapter for ½ - 14 NPT)</p> <p>WirelessHART™: Only M20 X 1.5</p>
<p>Process Connection</p>	<p>Process Connection: ¼ - 18 NPT or ½ -14 NPT (with adapter). See ordering code for more options. For level transmitters, please see ordering code.</p>
<p>Wetted Parts</p>	<p>Isolating Diaphragms: 316L SST, Hastelloy C276, Monel 400 or Tantalum.</p> <p>Drain/Vent Valves and Plug: Plated Carbon Steel, 316 SST, Hastelloy C276 or Monel 400.</p> <p>Flanges: Plated Carbon Steel, 316 SST CF8M (ASTM - A351), Hastelloy C276 - CW-12MW, (ASTM - A494) or Monel 400.</p> <p>Wetted O’Ring (For Flanges and Adapters): Buna-N, Viton™, PTFE or Ethylene-Propylene. The LD400 is available in NACE MR-01-75/ISO 15156 compliant materials.</p>
<p>Nonwetted Parts</p>	<p>Electronic Housing: Injected aluminum with epoxy painting or 316 SST - CF8M (ASTM - A351) housing. Complies with NEMA 4X/6P, IP66 or IP66W* and IP68 or IP68W*. <small>*The IP66/68W sealing test (immersion) was performed at 1 bar for 24 hours. For any other situation, please consult Smar. IP66/68W tested for 200h according to NBR 8094 / ASTM B 117 standard.</small></p> <p>Blank Flange: When flange adapter and Drain/Vent material are in Carbon Steel, blank flange is in Carbon Steel, otherwise blank flange is in 316 SST CF8M (ASTM - A351).</p> <p>Level Flange (LD400L): 316 L.</p> <p>Fill Fluid: Silicone, Fluorolube, Krytox, Halocarbon 4.2 or Fomblim oils.</p> <p>Cover O’Ring: Buna-N.</p> <p>Mounting Bracket: Plated Carbon Steel or 316 SST. Accessories (bolts, nuts, washers and U-clamps) in Carbon Steel or 316 SST.</p> <p>Flange Bolts and Nuts: Plated Carbon Steel, Grade 8 or 316 SST. For NACE applications: Carbon Steel ASTM A193 B7M.</p> <p>Identification Plate: 316 SST.</p>
<p>Mounting</p>	<p>a) Flange mounted for Level models. b) Optional universal mounting bracket for surface or vertical/horizontal 2"-pipe (DN 50). c) Manifold Valve integrated to the transmitter. d) Directly on piping for closely coupled transmitter/orifice flange combinations.</p>
<p>Approximate Weights</p>	<p>3.15 kg (7 lb): all models, except level transmitters. 5.85 to 9.0 kg (13 lb to 20 lb): level transmitters depending on the flanges, extension and materials.</p>
<p>Control Functions Characteristics (Optional)</p>	<p>Control Block (PID) and Totalization (TOT) (not available for <i>WirelessHART™</i>). <i>Note: The PID block isn’t available for use in SIS mode.</i></p>

Hastelloy is a trademark of the Cabot Corp.
 Monel is a trademark of International Nickel Co.

Fluorolube is a trademark of Hooker Chemical Corp.
 Halocarbon is a trademark of Halocarbon.
 HART® is a trademark of HART® Communication Foundation.

All other trademarks are the property of their respective owners
 SmarPressureTransmitters are protected by US patent number 6,433,791

MODEL DIFFERENTIAL, FLOW, GAGE, ABSOLUTE AND HIGH STATIC PRESSURE TRANSMITTER									
LD400 Smart Pressure Transmitter									
COD.	Type	Range Limits			Range Limits			Turn Down	
		Min	Max	Unit	Min	Max	Unit	Max	
D0	Differential (23)	-1	1	kPa	-10	10	mbar	20	
D1	Differential and Flow	-5	5	kPa	-50	50	mbar	40	
D2	Differential and Flow	-50	50	kPa	-500	500	mbar	200	
D3	Differential and Flow	-250	250	kPa	-2500	2500	mbar	200	
D4	Differential and Flow	-2500	2500	kPa	-25	25	bar	200	
M0	Gage	-1	1	kPa	-10	10	mbar	20	
M1	Gage	-5	5	kPa	-50	50	mbar	40	
M2	Gage	-50	50	kPa	-500	500	mbar	200	
M3	Gage	-100	250	kPa	-1000	2500	mbar	200	
M4	Gage	-100	2500	kPa	-1	25	bar	200	
M5	Gage	-0.1	25	MPa	-1	250	bar	120	
M6	Gage	-0.1	40	MPa	-1	400	bar	120	
A0	Absolute	0	1	kPa	0	7.5	mmHg	20	
A1	Absolute	0	5	kPa	0	37	mmHga	20	
A2	Absolute	0	50	kPa	0	500	mbar	20	
A3	Absolute	0	250	kPa	0	2500	mbar	120	
A4	Absolute	0	2500	kPa	0	25	bar	120	
A5	Absolute	0	25	MPa	0	250	bar	120	
A6	Absolute	0	40	MPa	0	400	bar	120	
H2	Differential Pressure for High Static Pressure	-50	50	kPa	-500	500	mbar	120	
H3	Differential Pressure for High Static Pressure	-250	250	kPa	-2500	2500	mbar	120	
H4	Differential Pressure for High Static Pressure	-2500	2500	kPa	-25	25	bar	120	
H5	Differential Pressure for High Static Pressure	-25	25	MPa	-250	250	bar	120	

Note: The range can be extended up to 0.75 LRL* and 1.2 URL** with small degradation of accuracy.
*LRL = Lower range limit
**URL = Upper range limit

COD. Diaphragm Material and Fill Fluid									
1	316L SST	Silicone Oil (9)	E	Hastelloy C276	Inert (Krytox Oil) (1) (12) (19)	S	Tantalum	Inert (Halocarbon 4.2 Oil) (3) (19)	
2	316L SST	Inert (Fluorolube Oil) (2) (19)	G	Tantalum	Inert (Krytox Oil) (3) (19)	T	GP 316L SST - OP	Inert (Halocarbon Oil) (3) (18) (19)	
3	Hastelloy C276	Silicone Oil (1) (9)	I	GP 316L SST - OP	Silicone Oil (3) (9) (18)	U	316L SST - OP	Silicone Oil (3) (9) (18)	
4	Hastelloy C276	Inert (Fluorolube Oil) (1) (19)	J	GP 316L SST - OP	Inert (Fluorolube Oil) (3) (4) (18) (19)	V	316L SST - OP	Inert (Fluorolube Oil) (3) (4) (18) (19)	
5	Monel 400	Silicone Oil (1) (3) (9)	K	Monel 400	Inert (Krytox Oil) (1) (3) (19)	W	316L SST - OP	Inert (Krytox Oil) (3) (18) (19)	
7	Tantalum	Silicone Oil (3) (9)	L	GP 316L SST - OP	Inert (Krytox Oil) (3) (18) (19)	X	316L SST - OP	Inert (Halocarbon Oil) (3) (18) (19)	
8	Tantalum	Inert (Fluorolube Oil) (2) (3) (19)	M	GP Monel 400	Silicone Oil (1) (3) (9)				
9	316L SST	Fomblim Oil (12)	P	GP Monel 400	Inert (Krytox Oil) (1) (3) (19)				
A	Monel 400	Fomblim Oil (1) (3)	Q	316L SST	Inert (Halocarbon 4.2 Oil) (19)				
D	316L SST	Inert (Krytox Oil) (12) (19)	R	Hastelloy C276	Inert (Halocarbon 4.2 Oil) (19)				

Note: GP= Gold Plated OP= Over-Lay Pot

COD. Performance Class									
0	Standard								
1	High Performance (15)								

COD. Communication Protocol										
H	HART® & 4 to 20 mA				W WirelessHART™					

COD. Safety Options									
0	Standard - For use in measurement and control								
1	SIS (Safety Instrumented Systems) (24) (27)								

COD. Flange(s), Adapter(s) and Drain/Vent Valves Material									
P	Plated CS (Drain/Vent In) (20)								
H	Hastelloy C276 (CW-12MW, ASTM - A494) (1)								
I	316 SST - CF8M (ASTM A351)								
F	Monel 400 Plated Bar (For HF Applications) (1)								
M	Monel 400 Microcasting (1)								
1	316 SST - CF8M (ASTM A351) (Drain/Vent In Hastelloy C276) (1)								
2	316 SST - CF8M (ASTM A351) Flange with PVDF (Kynar) Insert (5) (7) (11)								
3	316 SST - CF8M (Drain/Vent and plug in Monel) Nace Standard								

COD. Wetted O'Ring Materials									
0	Without O'Rings								
B	Buna-N								
E	Ethylene - Propylene (12)								
K	Kalrez (3)								
T	Teflon								
V	Viton								

Note: O'Rings are not available on the sides with Remote Seals.

COD. Drain/Vent Position									
0	Without Drain/Vent								
A	Drain/Vent (Opposite to Process Connection)								
D	Bottom								
U	Top								

Note: For better drain/vent operation, vent valves are strongly recommended.
Drain/vent valve not available on the sides with remote seals.

COD. Process Connection									
0	1/4 - 18 NPT (Without Adapter)								
1	1/2 - 14 NPT (With Adapter)								
3	Flange Seal with welded plug for Remote Seal (3) (8)								
5	1/2 - 14 NPT Axial with PVDF Insert (5) (7) (16)								
9	Low Volume Flange for Remote Seal (3) (4) (8)								
B	High Side: 1/2 - 14 NPT and Low Side: Flange with plug for Remote Seal (10) (3)								
D	High Side: Flange with plug for Remote Seal and Low Side: 1/2 - 14 NPT (10) (3)								
F	High Side: 1/2 - 14 NPT and Low Side: Low Volume Flange for Remote Seal (10) (3)								
H	High Side: Low Volume Flange for Remote Seal and Low Side: 1/2 - 14 NPT (10) (3)								
Q	8 mm hole without thread (According to DIN 19213) (13)								
T	1/2 - 14 BSP (With Adapter)								
V	Manifold Valve integrated to the transmitter								
Z	User's Specification								

COD. Special Applications									
0	Without Special Cleaning								
1	Degrease Cleaning (Oxygen, Hydrogen Peroxide or Chlorine Service) (14)								

LD400 - D2 | 1 | 0 - H | 0 - I | B | D | 1 | 1

← TYPICAL MODEL

LD400-D210-H0-IBD11	DIFFERENTIAL, FLOW, GAGE, ABSOLUTE AND HIGH STATIC PRESSURE TRANSMITTER		
COD. Flanges Bolts and Nuts Material			
P	Plated Carbon Steel (Default) (20)	A	Super Duplex Stainless Steel Nace MR0175 / MR0103 Compliant
I	316 SST		
C	Carbon Steel (ASTM A193 B7M) (1) (20)		
H	Hastelloy C276		
COD. Flange Thread for Fixing Accessories (Adapters, Manifolds, Mounting Brackets, etc)			
0	7/16 UNF	1	M10 X 1.5
		2	M12 X 1.75
COD. Local Indicator			
0	Without Indicator		
1	With Digital Indicator		
COD. Electrical Connection			
0	1/2 - 14 NPT (22) (27)		
1	3/4 - 14 NPT (with 316 SST adapter for 1/2 - 14 NPT) (22) (27)		
2	3/4 - 14 BSP (with 316 SST adapter for 1/2 - 14 NPT) (6) (27)		
3	1/2 - 14 BSP (with 316 SST adapter for 1/2 - 14 NPT) (6) (27)		
A	M20 X 1.5 (22)		
B	PG 13.5 DIN (22) (27)		
Z	User's Specification		
COD. Blind Plug			
I	316 SST		
C	Carbon Steel (Only available for 1/2" process connection) (20)		
COD. Mounting Bracket for 2" Pipe or Surface Mounting			
0	Without bracket		
1	Carbon Steel bracket and accessories (20)		
2	316 SST bracket and accessories		
5	L type, Carbon Steel bracket and accessories (20)		
6	L type, 316 SST bracket and accessories		
7	Carbon Steel bracket. Accessories: 316 SST (20)		
9	L type, Carbon Steel bracket. Accessories: 316 SST (20)		
A	Flat, 304 SST bracket and 316 SST accessories		
Z	User's Specification		
COD. Housing Material (25) (26)			
A	Aluminum (Default) (IP/TYPE)		
I	316 SST - CF8M (ASTM - A351) (IP/TYPE)		
J	316 SST for Salines Atmospheres (IPW/TYPEX) (21)		
B	Aluminium for Salines Atmospheres (IPW/TYPEX) (21)		
COD. Painting			
0	Gray Munsell N 6,5 Polyester		
8	Without Painting (17)		
9	Safety Blue Epoxy - Electrostatic Painting		
C	Safety Blue Polyester - Electrostatic Painting		
Z	User's Specification		
COD. Certification Type for Hazardous Locations			
N	No Certification		
I	Intrinsic Safety		
E	Increased Safety		
D	Explosion Proof		
F	Non-incendive + Intrinsic Safety		
G	Explosion Proof + Increased Safety		
H	Intrinsic Safety + Explosion Proof + Increased Safety		
J	Non-incendive + Intrinsic Safety + Dust (Dust ignition)		
COD. Certifying Body for Hazardous Locations			
0	None		
1	FM (Pending)		
5	CEPEL		
COD. Tag Plate			
0	With tag, when specified (Default)		
1	Blank		
2	User's Specification		
COD. HART® Configuration			
	**		

LD400-D210-H0-IBD11 - P 0 1 - 0 I 1 - A 0 N 0 0 / **

← TYPICAL MODEL

** Fill in with HART® optional configuration (see page 18)

Notes:									
<p>(1) Meets NACE MR-01-75/ISO 15156 recommendations. (2) Not available for absolute models nor for vacuum applications. (3) Not available for range 0 and 1. (4) Not recommended for vacuum service. (5) Maximum pressure 24 bar. (6) Options not certified for use in hazardous locations. (7) Drain/Vent not applicable. (8) For remote seal only 316 SST - CF8M (ASTM A351) flange is available (7/16 UNF). (9) Silicone Oil is not recommended for oxygen (O₂) or Chlorine service. (10) Only available for differential pressure transmitters. (11) O'Ring should be Viton or Kalrez. (12) Not available for range 0. (13) Only available for pressure transmitters D4 or H4 and 7/16 UNF or M10 x 1.5 flang thread for fixing accessories. (14) Degrease cleaning not available for carbon steel flanges. (15) Only available for differential and gage models. (16) Only available for flange with PVDF (Kynar) insert.</p>	<p>(17) Not available for aluminum housing. (18) Effective for hydrogen migration process. (19) Not applicable for saline atmosphere. (20) Not applicable for saline atmosphere. (21) IPW/TYPEX tested for 200h to according NBR 8094 / ASTM B 117 standard. (22) Certificate for use in Explosion Proof (CEPEL). (23) The D0 range should not be used for flow measurement. (24) SIL 1 and SIL 2 (non-redundant) and SIL 3 (redundant) applications. (25) IPX8 tested in 10 meters of water column for 24 hours. (26) Ingress Protection:</p>								
<table border="1" style="margin: auto; border-collapse: collapse;"> <thead> <tr style="background-color: #0056b3; color: white;"> <th style="padding: 5px;">Products</th> <th style="padding: 5px;">CEPEL</th> <th style="padding: 5px;">NEMKO / EXAM</th> <th style="padding: 5px;">FM</th> </tr> </thead> <tbody> <tr> <td style="text-align: center; padding: 5px;">LD400</td> <td style="text-align: center; padding: 5px;">IP66/68W</td> <td style="text-align: center; padding: 5px;">IP66/68W</td> <td style="text-align: center; padding: 5px;">Type 4X/6P</td> </tr> </tbody> </table>		Products	CEPEL	NEMKO / EXAM	FM	LD400	IP66/68W	IP66/68W	Type 4X/6P
Products	CEPEL	NEMKO / EXAM	FM						
LD400	IP66/68W	IP66/68W	Type 4X/6P						
<p>(27) Not available for <i>WirelessHART™</i> protocol.</p>									

MODEL		FLANGED PRESSURE TRANSMITTER										
LD400		Smart Pressure Transmitter										
COD.	Type	Range Limits			Range Limits			Turn Down				
		Min	Max	Unit	Min	Max	Unit	Max				
L2	Level	-50	50	kPa	500	500	mbar	120	Note: The range can be extended up to 0.75 LRL and 1.2 URL with small degradation of accuracy. The upper range value must be limited to the flange rating.			
L3	Level	-250	250	kPa	-2500	2500	mbar	120				
L4	Level	-2500	2500	kPa	-25	25	bar	120				
L5	Level	-25	25	MPa	-250	250	bar	120				
COD.		Diaphragm Material and Fill Fluid										
1	316L SST	Silicone Oil (2)			E	Hastelloy C276	Inert (Krytox Oil) (1) (18)		S	Tantalum	Inert (Krytox 4.2 Oil) (18)	
2	316L SST	Inert (Fluorolube Oil) (3) (18)			G	Tantalum	Inert (Krytox Oil) (18)		T	GP 316L SST - OP	Inert (Krytox Oil) (16) (18)	
3	Hastelloy C276	Silicone Oil (1) (2)			I	GP 316L SST - OP	Silicone Oil (9) (16)		U	316L SST - OP	Silicone Oil (9) (16)	
4	Hastelloy C276	Inert (Fluorolube Oil) (1) (3) (18)			J	GP 316L SST - OP	Inert (Fluorolube Oil) (3) (16) (18)		V	316L SST - OP	Inert (Fluorolube Oil) (3) (16) (18)	
5	Monel 400	Silicone Oil (1) (2)			K	Monel 400	Inert (Krytox Oil) (1) (18)		W	316L SST - OP	Inert (Krytox Oil) (16) (18)	
7	Tantalum	Silicone Oil (2)			L	GP 316L SST - OP	Inert (Krytox Oil) (16) (18)		X	316L SST - OP	Inert (Krytox Oil) (16) (18)	
8	Tantalum	Inert (Fluorolube Oil) (3) (18)			M	GP Monel 400	Silicone Oil (1) (2)					
9	316L SST	Fomblim Oil			P	GP Monel 400	Inert (Krytox Oil) (1) (18)					
A	Monel 400	Fomblim Oil (1)			Q	316L SST	Inert (Krytox 4.2 Oil) (18)					
D	316L SST	Inert (Krytox Oil) (18)			R	Hastelloy C276	Inert (Krytox 4.2 Oil) (1) (18)		Note: GP= Gold Plated OP= Over-Lay Pot			
COD.		Performance Class										
0	Standard											
COD.		Communication Protocol										
H	HART® & 4 to 20 mA			W			WirelessHART™					
COD.		Safety Options										
0	Standard – For use in measurement and control					1					SIS (Safety Instrumented Systems) (25) (29)	
COD.		Flange(s), Adapter(s) and Drain/Vent Valves Material										
A	304L SST			F			Monel 400 Plated Bar (For HF Applications) (1)					
P	Plated CS (Drain/Vent In Stainless Steel) (19)			M			Monel 400 Microcasting (1)					
H	Hastelloy C276 (CW-12MW, ASTM - A494)			1			316 SST - CF8M (ASTM A351) (Drain/Vent In Hastelloy C276) (1)					
I	316 SST - CF8M (ASTM A351) (1)			2			316 SST - CF8M (ASTM A351) Flange with PVDF (Kynar) Insert (3) (4) (5)					
COD.		Wetted O'Ring Materials										
0	Without O'Rings			K			Kalrez					
B	Buna-N			T			Teflon					
E	Ethylene - Propylene			V			Viton					
COD.		Drain/Vent Position (Low Side)										
0	Without Drain/Vent											
A	Drain/Vent (Opposite to Process Connection)											
D	Bottom											
U	Top											
COD.		Process Connection (Low Side)										
0	1/4 - 18 NPT (Without Adapter)			T			1/2 - 14 BSP (With Adapter)					
1	1/2 - 14 NPT (With Adapter)			U			Flange for Level with Welded Plug					
3	Remote Seal (With Plug) (7)			V			Without Connection (Mounted with Gage Flange)					
5	1/2 - 14 NPT Axial with PVDF Insert (3) (4) (6)			Z			User's Specification					
9	Remote Seal (Low Volume Flange) (3) (7)											
COD.		Special Applications										
0	No Special Cleaning											
1	Degrease Cleaning (Oxygen or Chlorine Service) (11)											
2	Vacuum Applications											
COD.		Flanges Bolts and Nuts Material (Low Side)										
P	Plated Carbon Steel (Default) (19)			H			Hastelloy C276					
I	316 SST											
C	Carbon Steel (ASTM A193 B7M) (1) (19)											
COD.		Flange Thread for Fixing Accessories (Adapters, Manifolds, Mounting Brackets, etc)										
0	7/16 UNF (Default)											
1	M10 X 1.5											
2	M12 X 1.75											
COD.		Process Connection (High Side)										
U	1" 150 # (ANSI B16.5) (28)			D			4" 600 # (ANSI B16.5)					
V	1" 300 # (ANSI B16.5) (28)			R			DN 25 PN10/40 (DIN EN 1092-1) (28)					
W	1" 600 # (ANSI B16.5) (28)			5			DN 40 PN10/40 (DIN EN 1092-1) (22)					
O	1 1/2" 150 # (ANSI B16.5) (22)			E			DN 50 PN 10/40 (DIN EN 1092-1) (22)					
P	1 1/2" 300 # (ANSI B16.5) (22)			6			DN 80 PN 10/40 (DIN EN 1092-1) (22)					
Q	1 1/2" 600 # (ANSI B16.5) (22)			7			DN 100 PN 10/16 (DIN EN 1092-1) (22)					
9	2" 150 # (ANSI B16.5)			8			DN 100 PN 25/40 (DIN EN 1092-1) (22)					
A	2" 300 # (ANSI B16.5)			H			10K 100A (JIS 2202) (22)					
B	2" 600 # (ANSI B16.5)			F			10K 50A (JIS 2202) (22)					
1	3" 150 # (ANSI B16.5)			G			10K 80A (JIS 2202) (22)					
2	3" 300 # (ANSI B16.5)			M			20K 100 (JIS 2202) (22)					
C	3" 600 # (ANSI B16.5)			S			20K 40A (JIS 2202) (22)					
N	3" 600 # (ANSI B16.5 RTJ)			K			20K 50A (JIS 2202) (22)					
3	4" 150 # (ANSI B16.5)			L			20K 80A (JIS 2202) (22)					
4	4" 300 # (ANSI B16.5)			Z			User's Specification (22)					
COD.		Type and Flange Material (High Side)										
I	316L SST (Integral Flange)			K			316 SST (Slip-on Flange)					
H	Hastelloy C276 (Integral Flange)			L			Carbon Steel (Slip-on Flange)					
J	304 SST (Slip-on Flange)			Z			User's Specification					
COD.		Flange Facing Finish										
0	Raised Face - RF			4			Small Grooved Face (14) (15)					
1	Flat Face - FF (14)			5			Large Tongue Face (14) (15)					
2	Ring Joint Face - RTJ (13)			6			Large Grooved Face (14) (15)					
3	Small Tongue Face (14) (15)											

LD400 - L2 1 0 - H 0 - P B D 0 0 - P 0 1 - I 0



LD400-L210-H0-PBD00-P01-10		FLANGED PRESSURE TRANSMITTER	
COD. Extension Length			
0	0 mm (0")		
1	50 mm (2")		
2	100 mm (4")		
3	150 mm (6")		
4	200 mm (8")		
Z	User's Specification		
Note: Extension Material: 316 SST			
COD. Diaphragm Material (Level Tap)			
A	304L SST	T	Tantalum (10)
L	316L SST	X	Titanium (10)
H	Hastelloy C276	1	316L SST with Teflon Lining (For 2" and 3")
M	Monel 400	2	316L SST Gold Plated
3			Tantalum with Teflon Lining
COD. Fill Fluid (Level Tap)			
1	DC-200/20 Silicone Oil	N	Neobee M20 Propylene Glycol Oil
2	Inert (Fluorolube MO-10 Oil) (8)	T	Syltherm 800 Oil
3	DC704 Silicone Oil	Z	User's Specification
4	Inert (Krytox Oil)		
COD. Local Indicator			
0	Without Local Indicator		
1	With Digital Indicator		
COD. Electrical Connection			
0	1/2 - 14 NPT (21) (29)	A	M20 X 1.5 (21)
1	3/4 - 14 NPT (with 316 SST adapter for 1/2 - 14 NPT) (21) (29)	B	PG 13.5 DIN (21) (29)
2	3/4 - 14 BSP (with 316 SST adapter for 1/2 - 14 NPT) (9) (29)	Z	User's Specification
3	1/2 - 14 BSP (with 316 SST adapter for 1/2 - 14 NPT) (9) (29)		
COD. Blind Plug			
I	316 SST	C	Carbon Steel (12) (19)
COD. Housing Material (26) (27)			
A	Aluminum (IP/TYPE)		
I	316 SST - CF8M (ASTM - A351) (IP/TYPE)		
J	316 SST for Salines Atmospheres (IPW/TYPEX) (20)		
B	Aluminium for Salines Atmospheres (IPW/TYPEX) (20)		
COD. Painting			
0	Gray Munsell N 6,5 Polyester		
8	Without Painting (16)		
9	Safety Blue Epoxy - Electrostatic Painting		
C	Safety Blue Polyester - Electrostatic Painting		
Z	User's Specification		
COD. Certification Type for Hazardous Locations			
N	No Certification		
I	Intrinsic Safety		
E	Increased Safety		
D	Explosion Proof		
F	Non-incendive + Intrinsic Safety		
G	Explosion Proof + Increased Safety		
H	Intrinsic Safety + Explosion Proof + Increased Safety		
J	Non-incendive + Intrinsic Safety + Dust (Dust ignition)		
COD. Certifying Body for Hazardous Locations			
0	None	1	FM (Pending)
		5	CEPEL
COD. Tag Plate			
0	With tag, when specified (Default)		
1	Blank		
2	User's Specification		
COD. Lower Housing Connection			
0	Without Lower Housing Connection (24)	3	Super Duplex (UNS 32750) (23)
1	Stainless Steel 316	4	Duplex (UNS 31803) (23)
2	Hastelloy C276	5	Stainless Steel 304L (23)
COD. Gasket Material			
0	Without gasket		
T	Teflon (Ptfе)		
G	Grafol (Flexible lead)		
C	Copper		
I	Stainless 316 SST		
COD. HART® Configuration			
**			

LD400-L210-H0-PBD00-P01-10 - 1 | L | 1 | 1 | 0 | I | - | A | 0 | N | 0 | 0 | 2 | T | / | **



** Fill in with HART® optional configuration (see page 18)

Notes:

- (1) Meets NACE MR-01-75/ISO 15156 recommendations.
- (2) Silicone Oil is not recommended for Oxygen (O₂) or Chlorine service.
- (3) Not applicable for vacuum service.
- (4) Drain/Vent not applicable.
- (5) O'Ring should be Viton or Kalrez.
- (6) Maximum pressure 24 bar.
- (7) For Remote Seal only 316 SST CF8M (ASTM A351) flange is available (7/16 UNF).
- (8) Fluorolube fill fluid is not available for Monel diaphragm.
- (9) Options not certified for use in hazardous locations.
- (10) Attention, check corrosion rate for the process, tantalum plate 0.1 mm, AISI 316L extension 3 to 6mm.
- (11) Degrease cleaning not available for carbon steel flanges.
- (12) Only available for 1/2" electrical connection.
- (13) Only available for flange ANSI B16.5.
- (14) Not available for flange JIS 2202.
- (15) For this option consult Smar.
- (16) Not available for Aluminum housing.
- (17) Effective for hydrogen migration process.

- (18) Inert Fluid: safe for oxygen service.
- (19) Not applicable for saline atmosphere.
- (20) IPW/TYPEX tested for 200h to according with standard NBR 8094 / ASTM B 117.
- (21) Certificate for use in Explosion Proof (CEPEL).
- (22) Not available for slip-on flange.
- (23) Item by inquiry.
- (24) Supplied without gasket.
- (25) SIL 1 and SIL 2 (non-redundant) and SIL 3 (redundant) applications.
- (26) IPX8 tested in 10 meters of water column for 24 hours.
- (27) Ingress Protection:

Products	CEPEL	NEMKO / EXAM	FM
LD400	IP66/68W	IP66/68W	Type 4X/6P

- (28) Not available for integral flange.
- (29) Not available for WireLessHAR™ protocol.

MODEL	PRESSURE TRANSMITTER WITH EXTENDED PROBE				
LD400	Pressure Transmitter With Extended Probe				
COD.	TYPE	Range Limits			
		Min	Max	Unit	
I2	Level	12,5	500	mbar	
COD.	Diaphragm material and Fill Fluid (Low Side)				
1	316L SST	Silicon Oil (9)			
COD.	Performance Class				
0	Default				
COD.	Communication Protocol				
H	HART® and 4 to 20 mA		W	WirelessHART™	
COD.	Security Option				
0	Default- For use in measurement and control			1	SIS - Safety Instrumented Systems (26)
COD.	Probe Material				
A	304L SST / 316L SST				
H	Hastelloy C276 / Hastelloy C276				
I	316L SST / 316L SST				
U	316L SST / Hastelloy C276				
Z	User's Specification				
COD.	Probe Length				
1	500 mm	6	1600 mm		
2	630 mm	7	2000 mm		
3	800 mm	8	2500 mm		
4	1000 mm	9	3200 mm		
5	1250 mm	Z	User's Specification		
COD.	Probe Fill Fluid				
N	Propilen Glicol Oil (Neobee M20)				
COD.	Fixing Transmitter				
1	Support in L	4	Fixed Flanged Support		
2	Adjustable Flanged Support	Z	User's Specification		
3	Triclamp diameter 3"				
COD.	Special Applications				
0	Without Special Applications				
1	Degrease Cleaning (Oxygen or Chlorine Service) (15)				
COD.	Local Indicator				
0	Without Local Indicator				
1	With Local Indicator				
COD.	Electrical Connection				
0	1/2 - 14 NPT (22)				
1	3/4- 14 NPT (With Adapter 316 SST para 1/2 - 14 NPT) (22)				
2	3/4- 14 BSP (With Adapter 316 SST para 1/2 - 14 NPT) (6)				
3	1/2 - 14 BSP (With Adapter 316 SST para 1/2 - 14 NPT) (6)				
A	M20 X 1.5 (22)				
B	PG 13.5 DIN (22)				
Z	User's Specification				
COD.	Blanket Plug				
I	316 SST				
C	Carbon Steel (Only available for process connection with 1/2") (20)				
COD.	Housing Material				
A	Aluminium				
I	316 SST - CF8M (ASTM - A351)				
J	316 SST - saline atmosphere (21)				
B	Aluminium - saline atmosphere (21)				
COD.	Painting				
0	Gray Munsell N6.5 Polyesters				
8	Without painting (17)				
9	Safety Blue Epoxy - Electrostatic Painting				
C	Safety Blue Polyesters - Electrostatic Painting				
Z	Special Painting				
COD.	Certification Type for Hazardous Locations				
N	Without certification				
I	Intrinsic Safety				
E	Increased Safety				
D	Explosion Proof				
F	Non-incendive + Intrinsic Safety				
G	Explosion Proof + Increased Safety				
H	Intrinsic Safety + Explosion Proof + Increased Safety				
J	Non-incendive + Intrinsic Safety + Dust				
COD.	Identification Plate for Hazardous Locations				
0	Without Certified Organ		5	CEPEL	
1	FM (Pendente)		6	Without certification	
2	NEMKO		7	EXAM (DTM)	
3	CSA				
4	EXAM (DTM), NEMKO				
COD.	Tag Plate				
0	With tag, when specified				
1	Blanket				
2	User's Specification				

LD400 - I2 1 0 - H 0 - I 9 N 2 0 - I 0 1 - A 0 N 0 0

CONTINUE IN THE NEXT PAGE

Notes:

- (1) Meets NACE MR - 01 - 75/ISO 15156 recommendations.
- (2) Not available for absolute models nor vacuum applications.
- (3) Not applicable for ranges 0 and 1.
- (4) Not applicable for vacuum service.
- (5) Pressure maximum: 24 bar.
- (6) Options not certified for use in hazardous locations.
- (7) Drain/Vent not applicable.
- (8) For Remote Seal only 316 SST CF8M (ASTM A351) flange is available (thread 7/16 UNF).
- (9) Silicone Oil is not recommended for Oxygen (O2) or Chlorine service.
- (10) Only available for differential pressure transmitter.
- (11) O'Ring material must be of Viton or Kalrez.
- (12) Not applicable for ranges 0.
- (13) Only available for pressure transmitters D4 or H4 and 7/16 UNF or M10 x 1.5 flange thread for fixing accessories.
- (14) Only available for LD400D and LD400M.
- (15) Degrease cleaning not available for carbon steel flanges.
- (16) Only available for Flange with PVDF (Kynar) Insert.

- (17) Not available for aluminium housing.
- (18) Effective for hydrogen migration processes.
- (19) Inert Fluid: Oxygen Compatibility, safe for oxygen service.
- (20) Not applicable for saline atmosphere.
- (21) IPW/TYPEx tested for 200h to according NBR 8094 / ASTM B 117 standard.
- (22) Certificate for use in Explosion Proof (CEPEL).
- (23) The D0 range should not be used for flow measurement.
- (24) IPX8 tested in 10 meters of water column for 24 hours.
- (25) Ingress Protection:

Product	CEPEL	NEMKO / EXAM	FM
LD400	IP66/68W	IP66/68W	Type 4X/6P

(26) Not available for WirelessHART™ protocol.

MODEL	SANITARY PRESSURE TRANSMITTER										
LD400	Smart Pressure Transmitter										
COD.	Type	Range Limits			Range Limits			Turn Down		Note: The range can be extended up to 0.75 LRL and 1.2 URL with small degradation of accuracy. The upper range value must be limited to the flange rating.	
		Min	Max	Unit	Min	Max	Unit	Max			
S2	Sanitary	-50	50	kPa	-500	500	mbar	120			
S3	Sanitary	-250	250	kPa	-2500	2500	mbar	120			
S4	Sanitary	-2500	2500	kPa	-25	25	bar	120			
S5	Sanitary	-25	25	MPa	-250	250	bar	120			
COD.	Diaphragm Material and Fill Fluid										
1	316L SST	Silicone Oil (2)			J	GP 316L SST - OP	Inert (Fluorolube Oil) (3) (14) (16)				
2	316L SST	Inert (Fluorolube Oil) (3) (16)			K	Monel 400	Inert (Krytox Oil) (1) (16)				
3	Hastelloy C276	Silicone Oil (1) (2)			L	GP 316L SST - OP	Inert (Krytox Oil) (14) (16)				
4	Hastelloy C276	Inert (Fluorolube Oil) (1) (3) (16)			M	GP Monel 400	Silicone Oil (1) (2)				
5	Monel 400	Silicone Oil (1) (2)			P	GP Monel 400	Inert (Krytox Oil) (1) (16)				
7	Tantalum	Silicone Oil (2)			Q	316L SST	Inert (Halocarbon 4.2 Oil) (16)				
8	Tantalum	Inert (Fluorolube Oil) (3) (16)			R	Hastelloy C276	Inert (Halocarbon 4.2 Oil) (1) (16)				
9	316L SST	Fomblin Oil			S	Tantalum	Inert (Halocarbon 4.2 Oil) (16)				
A	Monel 400	Fomblin Oil (1)			T	GP 316L SST - OP	Inert (Halocarbon Oil) (14) (16)				
D	316L SST	Inert (Krytox Oil) (16)			U	316L SST - OP	Silicone Oil (9) (14)				
E	Hastelloy C276	Inert (Krytox Oil) (1) (16)			V	316L SST - OP	Inert (Fluorolube Oil) (3) (14) (16)				
G	Tantalum	Inert (Krytox Oil) (16)			W	316L SST - OP	Inert (Krytox Oil) (14) (16)				
I	GP 316L SST - OP	Silicone Oil (9) (14)			X	316L SST - OP	Inert (Halocarbon Oil) (14) (16)				
COD.	Performance Class										
0	Standard										
COD.	Communication Protocol										
H	HART® & 4 to 20 mA				W	WirelessHART™					
COD.	Safety Options										
0	Standard- For use in measurement and control										
1	SIS (Safety Instrumented Systems) (20) (24)										
COD.	Flange(s), Adapter(s) and Drain/Vent Valves Material										
H	Hastelloy C276 (CW-12MW, ASTM - A494)						I	CF8M / 316 SST			
COD.	Wetted O'Ring Materials (Low Side)										
0	Without O'Rings			K	Kalrez			Note: O'Rings are not available on the sides with Remote Seals.			
B	Buna-N			T	Teflon						
E	Ethylene - Propylene			V	Viton						
COD.	Drain/Vent Position (Low Side)										
0	Without Drain/Vent										
A	Drain/Vent (Opposite to Process Connection)										
D	Bottom										
U	Top										
COD.	Process Connection (Low Side)										
0	1/4 - 18 NPT (Without Adapter)					T	1/2 - 14 BSP (With Adapter)				
1	1/2 - 14 NPT (With Adapter)					U	Flange for Level with Welded Plug				
3	Remote Seal (With Plug) (7)					V	Without Connection (Mounted with Gage)				
5	1/2 - 14 NPT Axial with PVDF Insert (3) (4) (6)					Z	User's Specification				
9	Remote Seal (Low Volume Flange) (3) (7)										
COD.	Special Applications										
0	No Special Cleaning										
1	Degrease Cleaning (Oxygen or Chlorine Service) (11)										
2	For Vacuum Application										
COD.	Flanges Bolts and Nuts Material (Low Side)										
P	Plated Carbon Steel (19)						H	Hastelloy C276			
I	316 SST										
C	Carbon Steel (ASTM A193 B7M) (1) (19)										
COD.	Flange Thread for Fixing Accessories (Adapters, Manifolds, Mounting Brackets, etc)										
0	7/16 UNF										
1	M10 X 1.5										
2	M12 X 1.75										

LD400 - S2 | 1 | 0 | H | 0 | H | B | D | U | 0 | P | 0

← TYPICAL MODEL

LD400-S210-H0-HBDU0-P0		SANITARY PRESSURE TRANSMITTER	
COD. Process Connection (High Side)			
8	DN25 DIN 11851 - With Extension / 316 L SST (21)	7	Thread SMS 2" - With Extension / 316 L SST (21)
9	DN40 DIN 11851 - With Extension / 316 L SST (21)	E	Thread SMS 2" - 316 L SST (21)
H	DN40 DIN 11851 - 316 L SST	M	Thread SMS 3" - With Extension / 316 L SST (21)
V	Thread DN50 DIN 11851 - With Extension / 316 L SST (21)	F	Thread SMS 3" - Without Extension / 316 L SST (21)
U	Thread DN50 DIN 11851 - Without Extension / 316 L SST	1	Tri-Clamp 1 1/2" - 316 L SST (21)
X	Thread DN80 DIN 11851 - With Extension / 316 L SST (21)	Q	Tri-Clamp 1 1/2" HP (High Pressure) - 316 L SST (21)
W	Thread DN80 DIN 11851 - Without Extension / 316 L SST	6	Tri-Clamp 2" - With Extension / 316 L SST (21)
4	Thread IDF 2" - With Extension / 316 L SST (21)	D	Tri-Clamp 2" - 316 L SST (21)
B	Thread IDF 2" - 316 L SST (21)	N	Tri-Clamp 2" HP (High Pressure) - With Extension / 316 L SST (21)
K	Thread IDF 3" - With Extension / 316 L SST (21)	P	Tri-Clamp 2" HP (High Pressure) - 316 L SST (21)
3	Thread IDF 3" - Without Extension / 316 L SST (21)	I	Tri-Clamp 3" - With Extension / 316 L SST (21)
5	Thread RJT 2" - With Extension / 316 L SST (21)	J	Tri-Clamp 3" - 316 L SST (21)
C	Thread RJT 2" - 316 L SST	G	Tri-Clamp 3" HP (High Pressure) - With Extension / 316 L SST (21)
L	Thread RJT 3" - With Extension / 316 L SST (21)	R	Tri-Clamp 3" HP (High Pressure) - 316 L SST (21)
2	Thread RJT 3" - Without Extension / 316 L SST	Y	According to the Special Option
S	Thread SMS 1 1/2" - 316 L SST (21)	Z	User's Specification
COD. O-Ring Material (High Side)			
0	Without O-Ring (Supplied by customer)	B	Buna-N (21)
		T	Teflon (21)
		V	Viton (21)
		Z	User's Specification
COD. Tank Adapter			
0	Without Tank Adapter (Supplied by customer)	1	With tank, adapter in 316 SST
		Z	User's Specification
COD. TRI-CLAMP			
0	Without TRI-CLAMP (Supplied by customer)	2	With TRI-CLAMP in 304 SST (13)
		Z	User's Specification
COD. Diaphragm Material (High Side)			
I	316L SST	H	Hastelloy C276
COD. Fill Fluid (High Side)			
1	DC-200/20 Silicone Oil	4	Inert (Krytox Oil)
2	Inert (Fluorolube MO-10 Oil) (8)	N	Neobee M20 Propylene Glycol Oil (21)
3	DC704 Silicone Oil	T	Syltherm 800 Oil
		Z	User's Specification
COD. Local Indicator			
0	Without Indicator	1	With Digital Indicator
COD. Electrical Connection			
0	1/2 - 14 NPT (19)	A	M20 X 1.5 (19)
1	3/4 - 14 NPT (with 316 SST adapter for 1/2 - 14 NPT) (19) (24)	B	PG 13.5 DIN (19) (24)
2	3/4 - 14 BSP (with 316 SST adapter for 1/2 - 14 NPT) (9) (24)	Z	User's Specification
3	1/2 - 14 BSP (with 316 SST adapter for 1/2 - 14 NPT) (9) (24)		
COD. Blind Plug			
I	316 SST	C	Carbon Steel (12) (17)
COD. Housing Material (22) (23)			
A	Aluminum (IP/TYPE)	J	316 SST for Saline Atmospheres (IPW/TYPEX) (18)
I	316 SST - CF8M (ASTM - A351) (IP/TYPE)	B	Aluminium for Saline Atmospheres (IPW/TYPEX) (18)
COD. Painting			
0	Gray Munsell N 6,5 Polyester	C	Safety Blue Polyester - Electrostatic Painting
8	Without Painting (14)	Z	User's Specification
9	Safety Blue Epoxy - Electrostatic Painting		
COD. Certification Type for Hazardous Locations			
N	No Certification	F	Non-incendive + Intrinsic Safety
I	Intrinsic Safety	G	Explosion Proof + Increased Safety
E	Increased Safety	H	Intrinsic Safety + Explosion Proof + Increased Safety
D	Explosion Proof	I	Non-incendive + Intrinsic Safety + Dust (Dust ignition)
COD. Certifying Body for Hazardous Locations			
0	None	1	FM (Pending)
		5	CEPEL
COD. Tag Plate			
0	With tag, when specified (Default)	2	User's Specification
1	Blank		
COD. HART® Configuration (Continues Next Page)			
**			

LD400-S210-H0-HBDU0-P0 - 4 B 1 0 - I 1 1 0 I - A 0 N 0 0 / **



** Fill in with HART® optional configuration (see page 18)

Optional Items

Special Procedures	C4 - Polishing of the wet parts according to 3A Certification (21)								
Notes:									
<p>(1) Meets NACE MR-01-75/ISO 15156 recommendations.</p> <p>(2) Silicone Oil is not recommended for Oxygen (O₂) or Chlorine service.</p> <p>(3) Not applicable for vacuum service.</p> <p>(4) Drain/Vent not applicable.</p> <p>(5) O-ring should be Viton or Kalrez.</p> <p>(6) Maximum pressure 24 bar.</p> <p>(7) For Remote Seal only 316 SST CF8M (ASTM A351) flange is available (7/16 UNF).</p> <p>(8) Fluorolube fill fluid is not available for Monel diaphragm.</p> <p>(9) Options not certified for use in hazardous locations.</p> <p>(10) Not recommended with extension.</p> <p>(11) Degrease cleaning not available for carbon steel flanges.</p> <p>(12) Only available for 1/2" electrical connection.</p> <p>(13) Only available for TRI-CLAMP connection.</p> <p>(14) Not available for Aluminum housing.</p> <p>(15) Effective for hydrogen migration process.</p> <p>(16) Inert Fluid: safe for oxygen service.</p> <p>(17) Not applicable for saline atmosphere.</p>	<p>(18) IPW/TYPEX tested for 200h to according with standard NBR 8094 / ASTM B 117.</p> <p>(19) Certificate for use in Explosion Proof (CEPEL).</p> <p>(20) SIL1 and SIL2 (non-redundant) and SIL3 (redundant)</p> <p>(21) Compliant with 3A-7403 standard for food and other applications where sanitary connections are required: - Neobee M20 Fill Fluid - Finishing wet Face: 0,8 µm Ra (32 µ" AA) - Wet O-Ring: Viton, Buna-N and Teflon</p> <p>(22) IPX8 tested in 10 meters of water column for 24 hours.</p> <p>(23) Ingress Protection:</p>								
<table border="1"> <tr> <td>Products</td> <td>CEPEL</td> <td>NEMKO / EXAM</td> <td>FM</td> </tr> <tr> <td>LD400</td> <td>IP66/68W</td> <td>IP66/68W</td> <td>Type 4X/6P</td> </tr> </table>		Products	CEPEL	NEMKO / EXAM	FM	LD400	IP66/68W	IP66/68W	Type 4X/6P
Products	CEPEL	NEMKO / EXAM	FM						
LD400	IP66/68W	IP66/68W	Type 4X/6P						
(24) Not available for <i>WirelessHART™</i> protocol.									

MODEL	GAGE INLINE PRESSURE TRANSMITTER										
LD400	Smart Pressure Transmitter										
COD.	Type	Range Limits									
		Min	Max	Unit	Min	Max	Unit				
G2	Gage Inline	-50	50	KPa	-500	500	mbar				
G3	Gage Inline	-100	250	KPa	-1000	2500	mbar				
G4	Gage Inline	-100	2500	KPa	-1	25	bar				
G5	Gage Inline	-0,1	25	MPa	-1	2500	bar				
COD.	Diaphragm material and Fill Fluid										
1	316L SST	Silicon Oil (9)					D	316 SST L	Inert (Krytox Oil) (12) (19)		
2	316L SST	Inert (Fluorolube Oil) (2) (19)					E	Hastelloy C276	Inert (Krytox Oil) (1) (12) (19)		
3	Hastelloy C276	Silicon Oil (1) (9)					Q	316 SST L	Inert (Halocarbon 4.2 Oil) (19)		
4	Hastelloy C276	Inert (Fluorolube Oil) (1) (2) (19)					R	Hastelloy C276	Inert (Halocarbon 4.2 Oil) (19)		
COD.	Performance Class										
0	Default		1 High Performance (14)								
COD.	Communication Protocol										
H	HART® and 4 to 20 mA					W WirelessHART™					
COD.	Security Option										
0	Default - For use in measurement and control						1 SIS - Safety Instrumented Systems (26)				
COD.	Process Connection										
1	1/2 - 14 NPT (With Adapter)										
A	High Side: 1/4 NPT/ and Low Side: Seal with Plug										
G	High Side: 1/4 NPT and Low Side: Low Volume Flange										
H	High Side: Low Volume Flange for Remote Seal and Low Side: 1/2 - 14 NPT (10) (3)										
M	1/2 - 14 NPT Male										
R	Remote Seal										
U	1/2 BSP Male										
V	Valve Manifold Integrated with Transmitter										
X	1" NPT Sealed (Diaphragm in 316L SST, Silicon Fluid DC200/20)										
Z	User's Specification										
COD.	Process Connection Material										
H	Hastelloy C276			I 316L SST			Z User's Specification				
COD.	Special Applications										
0	Without Special Applications										
1	Degrease Cleaning (Oxygen or Chlorine Service) (15)										
COD.	Local Indicator										
0	Without Local Indicator						1 With Local Indicator				
COD.	Electrical Connection										
0	1/2 - 14 NPT (22)										
1	3/4 - 14 NPT (With Adapter 316 SST para 1/2 - 14 NPT) (22)										
2	3/4 - 14 BSP (With Adapter 316 SST para 1/2 - 14 NPT) (6)										
3	1/2 - 14 BSP (With Adapter 316 SST para 1/2 - 14 NPT) (6)										
A	M20 X 1.5 (22)										
B	PG 13.5 DIN (22)										
Z	User's Specification										
COD.	Blanket Plug										
I	316 SST										
C	Aço Carbono (Somente disponível para Process Connection de 1/2") (20)										
COD.	Mouting Bracket										
0	Without Bracket										
1	Carbon steel bracket and accessories (20)										
2	316 SST bracket and accessories										
7	Carbon steel bracket. Accessories: 316 SST (20)										
A	Flat, 304 SST bracket and 316 SST accessories										
COD.	Housing Material										
A	Aluminium (Default)										
I	316 SST - CF8M (ASTM - A351)										
J	316 SST - saline atmospheres (21)										
B	Aluminium - saline atmospheres (21)										
COD.	Painting										
0	Gray Munsell N 6.5 Polyester										
8	Without Painting (17)										
9	Safety Blue Epoxy - Electrostatic Painting										
C	Safety Blue Polyesters - Electrostatic Painting										
Z	Special Painting										
COD.	Certification Type for Hazardous Locations										
N	Without Certification										
I	Intrinsic Safety										
E	Increased Safety										
D	Explosion Proof										
F	Non-incendive + Intrinsic Safety										
G	Explosion Proof + Increased Safety										
H	Intrinsic Safety + Explosion Proof + Increased Safety										
J	Non-incendive + Intrinsic Safety + Dust										
COD.	Identification Plate for Hazardous Locations										
0	Without Identification Plate				5 CEPEL						
1	FM (Pendente)				6 Sem Certificação						
2	NEMKO				7 EXAM (DTM)						
3	CSA										
4	EXAM (DTM), NEMKO										
COD.	Tag Plate										
0	With tag, when specified										
1	Blank										
2	User's Specification										

LD400 - G3 1 0 - H 0 - 1 I 0 1 - 0 I 1 - A 0 N 0 0

CONTINUE IN THE NEXT PAGE

Notes:

- (1) Meets NACE MR - 01 - 75/ISO 15156 recommendations.
- (2) Not available for absolute models nor vacuum applications.
- (3) Not applicable for ranges 0 and 1.
- (4) Not applicable for vacuum service.
- (5) Pressure maximum: 24 bar.
- (6) Options not certified for use in hazardous locations.
- (7) Drain/Vent not applicable.
- (8) For Remote Seal only 316 SST CF8M (ASTM A351) flange is available (thread 7/16 UNF).
- (9) Silicone Oil is not recommended for Oxygen (O2) or Chlorine service.
- (10) Only available for differential pressure transmitter.
- (11) O'Ring material must be of Viton or Kalrez.
- (12) Not applicable for ranges 0.
- (13) Only available for pressure transmitters D4 or H4 and 7/16 UNF or M10 x 1.5 flange thread for fixing accessories.
- (14) Only available for LD400D and LD400M.
- (15) Degrease cleaning not available for carbon steel flanges.
- (16) Only available for Flange with PVDF (Kynar) Insert.

- (17) Not available for aluminium housing.
- (18) Effective for hydrogen migration processes.
- (19) Inert Fluid: Oxygen Compatibility, safe for oxygen service.
- (20) Not applicable for saline atmosphere.
- (21) IPW/TYPEx tested for 200h to according NBR 8094 / ASTM B 117 standard.
- (22) Certificate for use in Explosion Proof (CEPEL).
- (23) The D0 range should not be used for flow measurement.
- (24) IPX8 tested in 10 meters of water column for 24 hours.
- (25) Ingress Protection:

Product	CEPEL	NEMKO / EXAM	FM
LD400	IP66/68W	IP66/68W	Type 4X/6P

(26) Not available for *WirelessHART™* protocol.

**** Optional HART® Configuration ⁽¹⁾**

MODEL	MAIN CODE CONTINUED (FOR HART® TRANSMITTERS)										
	COD. Burn-out										
	BD	Down Scale (According to NAMUR NE43 specification) (Default)									
	BU	Up Scale (According to NAMUR NE43 specification)									
	COD. LCD1 Indication										
	Y0	LCD1: Percentage (Default)									
	Y1	LCD1: Current - I (mA)									
	Y2	LCD1: Pressure (Engineering Unit)									
	Y3	LCD1: Temperature (Engineering Unit)									
	YU	LCD1: User's Specification (2)									
	COD. LCD2 Indication										
	Y0	LCD1: Percentage (Default)									
	Y1	LCD2: Current - I (mA)									
	Y2	LCD2: Pressure (Engineering Unit)									
	Y3	LCD2: Temperature (Engineering Unit)									
	YU	LCD2: User's Specification (2)									
	COD. LCD3 Indication										
	Y0	LCD1: Percentage (Default)									
	Y1	LCD3: Current - I (mA)									
	Y2	LCD3: Pressure (Engineering Unit)									
	Y3	LCD3: Temperature (Engineering Unit)									
	YU	LCD3: User's Specification (2)									
	COD. PID Availability										
	P0	PID not available			P1	Available and disabled (Default)			P2	Available and enabled	
	COD. Transfer Function for Flow Measurement										
	F0	Linear (Default)									
	F1	SQRT - Square Root. Considering the pressure input X varying between 0 and 100%, the output will be $10\sqrt{x}$. This function is used in flow measurement with, e.g., orifice or Venturi tube etc. (3)									
	F2	SQRT**3 - Square Root of the Third Power. The output will be $0.1\sqrt{x^3}$. This function is used in open channel Flow measurement with weirs or flumes. (3)									
	F3	SQRT**5 - Square Root of the Fifth Power. The output will be $0.001\sqrt{x^5}$. This function is used in open channel Flow measurement with V-notch weirs. (3)									
	F4	TABLE - The output is a curve formed by 16 points. These points may be edited directly on the XY Table of the LD400. For example, it may be used as a camber table for tanks in applications where the tank volume is not linear in relation to the measured pressure.									
	F5	SQRT & TABLE - Square root and Table. Same application as square roots, but also allows additional compensation of, e.g., varying Reynolds number. (3)									
	F6	SQRT**3 & TABLE - Square Root of the Third Power and Table. (3)									
	F7	SQRT**5 & TABLE - Square Root of the Fifth Power and Table. (3)									
	F8	TABLE & SQRT - Table and Square root. Same application as square roots, but also allows bi-directional flow measurement by correcting the inverse flow, transforming the negative flow in positive flow, via table. (3)									
	COD. Special Features										
	M0	No Special Features (Default)									
	M4	Calibration by increasing and decreasing the pressure (Hysteresis)									
	M5	10-point calibration									
	M6	Special acquisition disabled									
	COD. Insulation Kit										
	K0	Without Insulation Kit									
	K1	With Insulation Kit (4)									
	COD. Special Features										
	ZZ	User's Specification									

LD400-D210-H0-IBD11-P01-011-A010	/	BU	Y2	Y3	Y1	P2	F1	M0	ZZ
LD400-L210-H0-PBD00-P01-I01-L1101-A010	/	BD	Y2	Y3	Y1	P2	M0	K1	ZZ
LD400-S210-H0-HBDU0-P04-B10-I1101-A060	/	BD	Y2	Y3	Y1	P2	M0	ZZ	

← TYPICAL MODEL

Notes:

- (1) Fill in only if selected option is different from the default value.
- (2) Values limited to 4 1/2 digits; unit limited to 12 characters.
- (3) Only available for differential, gage, absolute and high static pressure models.
- (4) Only available for level models.

LD400 - Differential Pressure, Flow, Gage, Absolute and High Static Pressure Transmitter

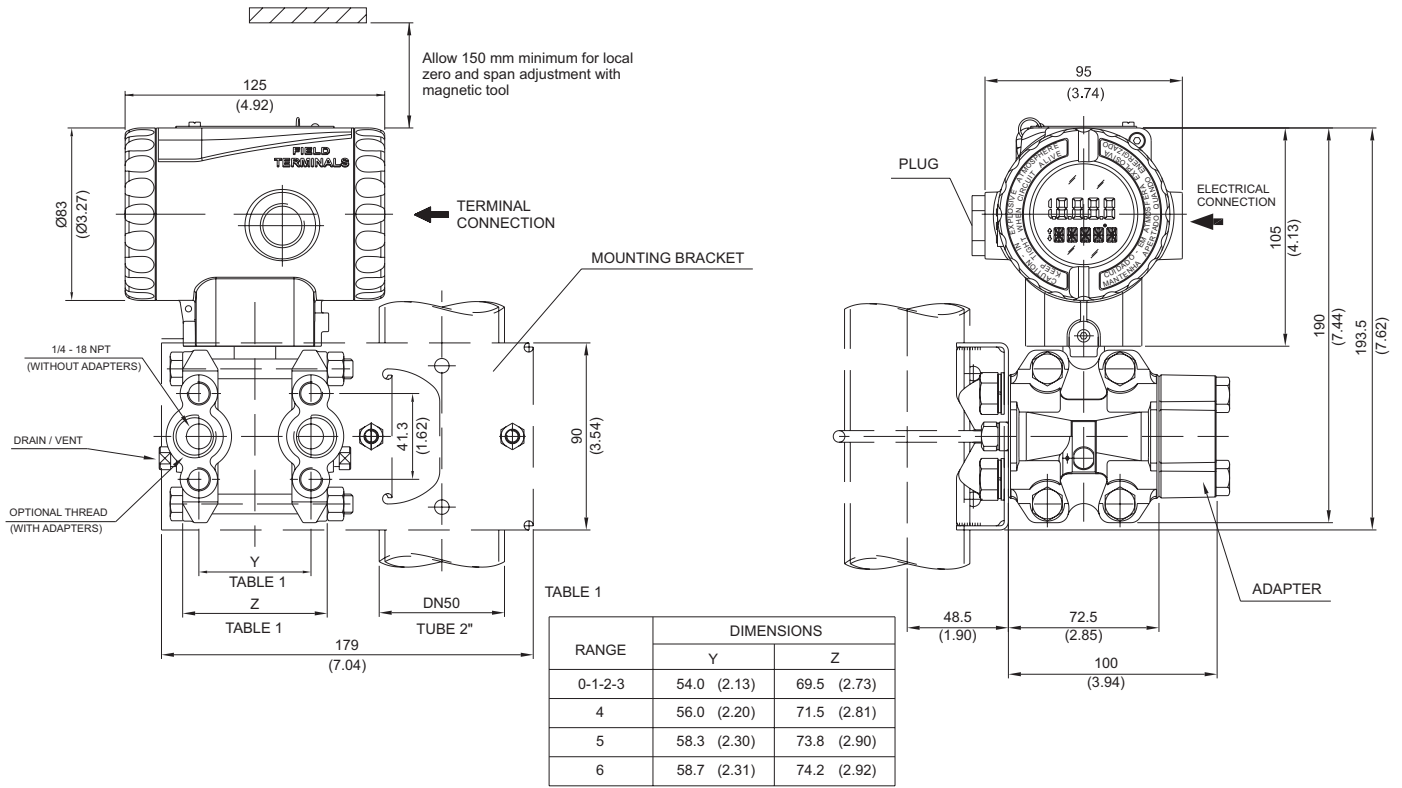

LD400 - Wireless Differential Pressure, Flow, Gage, Absolute and High Static Pressure Transmitter Wireless

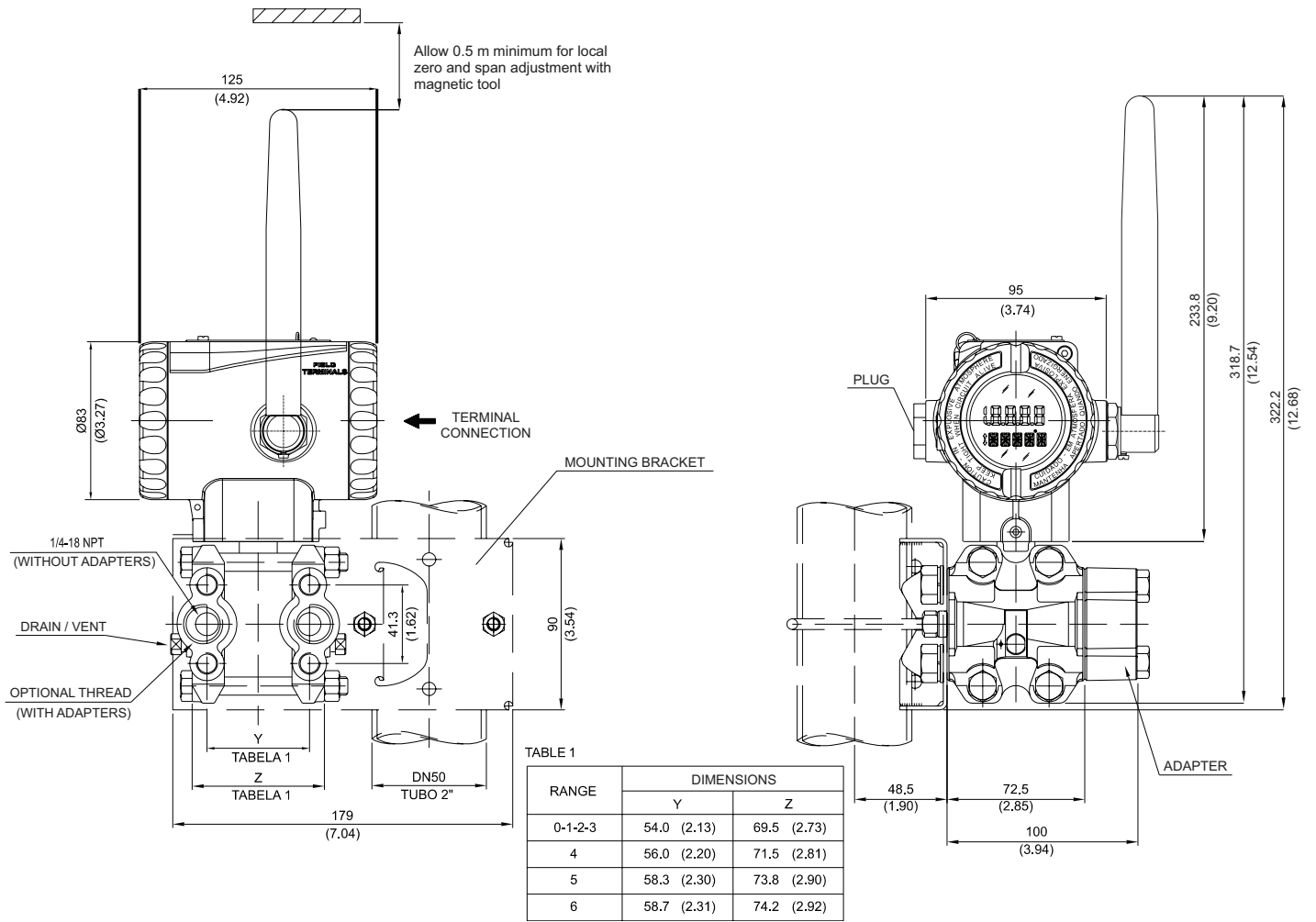

LD400L - Flanged Pressure Transmitter with Integral Flange

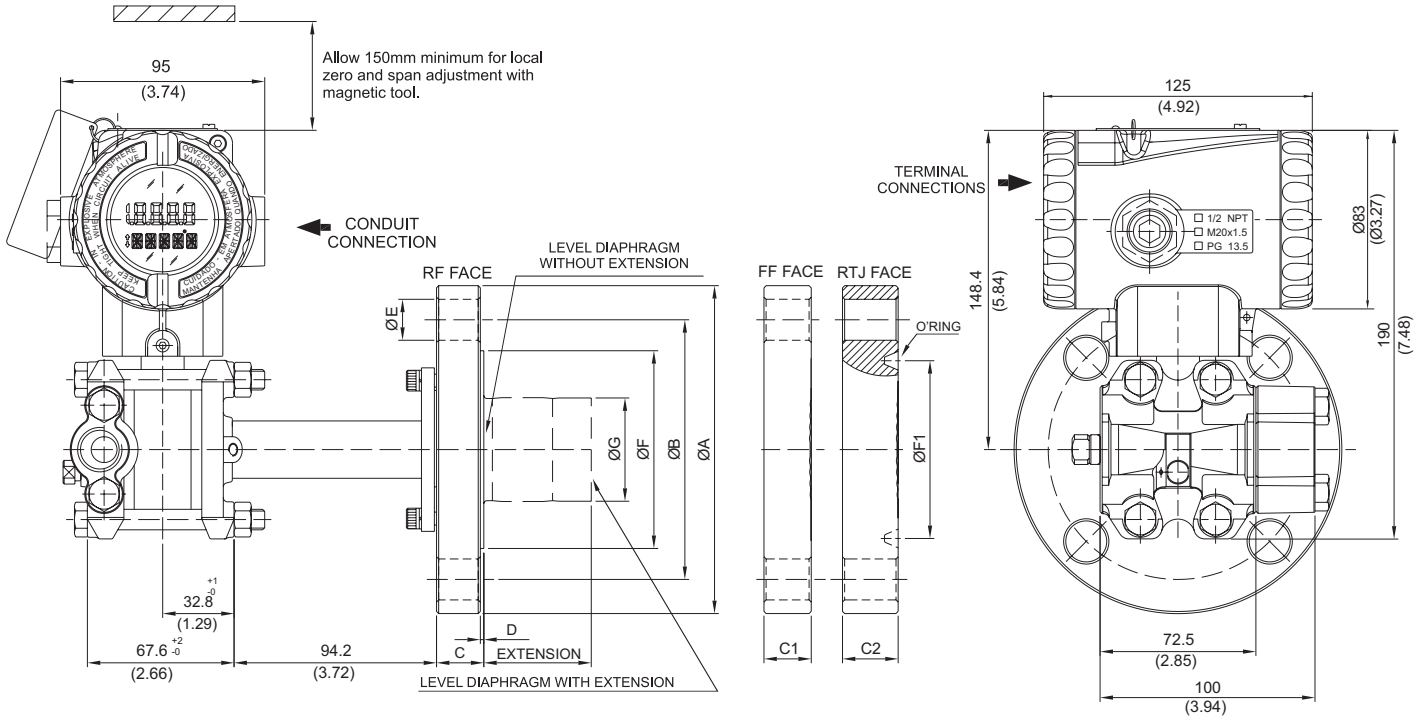

- Notes:
 - Extension length (mm): 0, 50, 100, 150 or 200
 - Dimensions are mm (in)

ANSI-B 16.5 DIMENSIONS													
DN	CLASS	A	B	C (RF)	C1 (FF)	C2 (RTJ)	D (RF)	E	F (RF)	F1 (RTJ)	RTJ O'RING	G	HOLES
1.1/2"	150	127 (5)	98.6 (3.88)	20 (0.78)	19 (0.75)	24.4 (0.96)	1.6 (0.06)	16 (0.63)	73.2 (2.88)	65.1 (2.56)	R19	40 (1.57)	4
	300	155.4 (6.12)	114.3 (4.5)	21 (0.83)	21 (0.83)	27.4 (1.07)	1.6 (0.06)	22 (0.87)	73.2 (2.88)	68.3 (2.68)	R20	40 (1.57)	4
	600	155.4 (6.12)	114.3 (4.5)	29.3 (1.15)	29.3 (1.15)	29.3 (1.15)	6.4 (0.25)	22 (0.87)	73.2 (2.88)	68.3 (2.68)	R20	40 (1.57)	4
2"	150	152.4 (6)	120.7 (4.75)	22 (0.87)	20 (0.78)	25.9 (1.02)	1.6 (0.06)	19 (0.75)	91.9 (3.62)	82.6 (3.25)	R22	48 (1.89)	4
	300	165.1 (6.5)	127 (5)	22.8 (0.9)	22.8 (0.89)	30.8 (1.21)	1.6 (0.06)	19 (0.75)	91.9 (3.62)	82.6 (3.25)	R23	48 (1.89)	8
	600	165.1 (6.5)	127 (5)	32.3 (1.27)	32.3 (1.27)	32.3 (1.27)	6.4 (0.25)	19 (0.75)	91.9 (3.62)	82.6 (3.25)	R23	48 (1.89)	8
3"	150	190.5 (7.5)	152.4 (6)	24.4 (0.96)	24.4 (0.96)	30.7 (1.21)	1.6 (0.06)	19 (0.75)	127 (5)	114.3 (4.50)	R29	73 (2.87)	4
	300	209.5 (8.25)	168.1 (6.62)	29 (1.14)	29 (1.14)	36.9 (1.45)	1.6 (0.06)	22 (0.87)	127 (5)	123.8 (4.87)	R31	73 (2.87)	8
	600	209.5 (8.25)	168.1 (6.62)	38.7 (1.52)	38.7 (1.52)	40.2 (1.58)	6.4 (0.25)	22 (0.87)	127 (5)	123.8 (4.87)	R31	73 (2.87)	8
4"	150	228.6 (9)	190.5 (7.5)	24.4 (0.96)	24.4 (0.96)	30.7 (1.21)	1.6 (0.06)	19 (0.75)	158 (6.22)	149.2 (5.87)	R36	96 (3.78)	8
	300	254 (10)	200 (7.87)	32.2 (1.27)	32.2 (1.27)	40.2 (1.58)	1.6 (0.06)	22 (0.87)	158 (6.22)	149.2 (5.87)	R37	96 (3.78)	8
	600	273 (10.75)	215.9 (8.5)	45 (1.77)	45 (1.77)	46.5 (1.83)	6.4 (0.25)	25 (1)	158 (6.22)	149.2 (5.87)	R37	96 (3.78)	8
EN 1092-1 DIMENSIONS													
DN	PN	A	B	C (RF)	C1 (FF)		D	E	F (RF)			G	HOLES
DN40	10/40	150 (5.9)	110 (4.33)	20 (0.78)	20 (0.78)		3 (0.12)	18 (0.71)	88 (3.46)			40 (1.57)	4
DN50	10/40	165 (6.5)	125 (4.92)	20 (0.78)	22 (0.86)		3 (0.12)	18 (0.71)	102 (4.01)			48 (1.89)	4
DN80	10/40	200 (7.87)	160 (6.3)	24 (0.95)	24 (0.94)		3 (0.12)	18 (0.71)	138 (5.43)			73 (2.87)	8
DN100	10/16	220 (8.67)	180 (7.08)	20 (0.78)			3 (0.12)	18 (0.71)	158 (6.22)			96 (3.78)	8
	25/40	235 (9.25)	190 (7.5)	24 (0.95)			3 (0.12)	22 (0.87)	162 (6.38)			96 (3.78)	8
JIS B 2202 DIMENSIONS													
DN	CLASS	A	B	C			D	E	F (RF)			G	HOLES
40A	20K	140 (5.5)	105 (4.13)	26 (1.02)			2 (0.08)	19 (0.75)	81 (3.2)			40 (1.57)	4
50A	10K	155 (6.1)	120 (4.72)	26 (1.02)			2 (0.08)	19 (0.75)	96 (3.78)			48 (1.89)	4
	40K	165 (6.5)	130 (5.12)	26 (1.02)			2 (0.08)	19 (0.75)	105 (4.13)			48 (1.89)	8
80A	10K	185 (7.28)	150 (5.9)	26 (1.02)			2 (0.08)	19 (0.75)	126 (4.96)			73 (2.87)	8
	20K	200 (7.87)	160 (6.3)	26 (1.02)			2 (0.08)	19 (0.75)	132 (5.2)			73 (2.87)	8
100A	10K	210 (8.27)	175 (6.89)	26 (1.02)			2 (0.08)	19 (0.75)	151 (5.95)			96 (3.78)	8

LD400L - Wireless Flanged Pressure Transmitter with Integral Flange Wireless

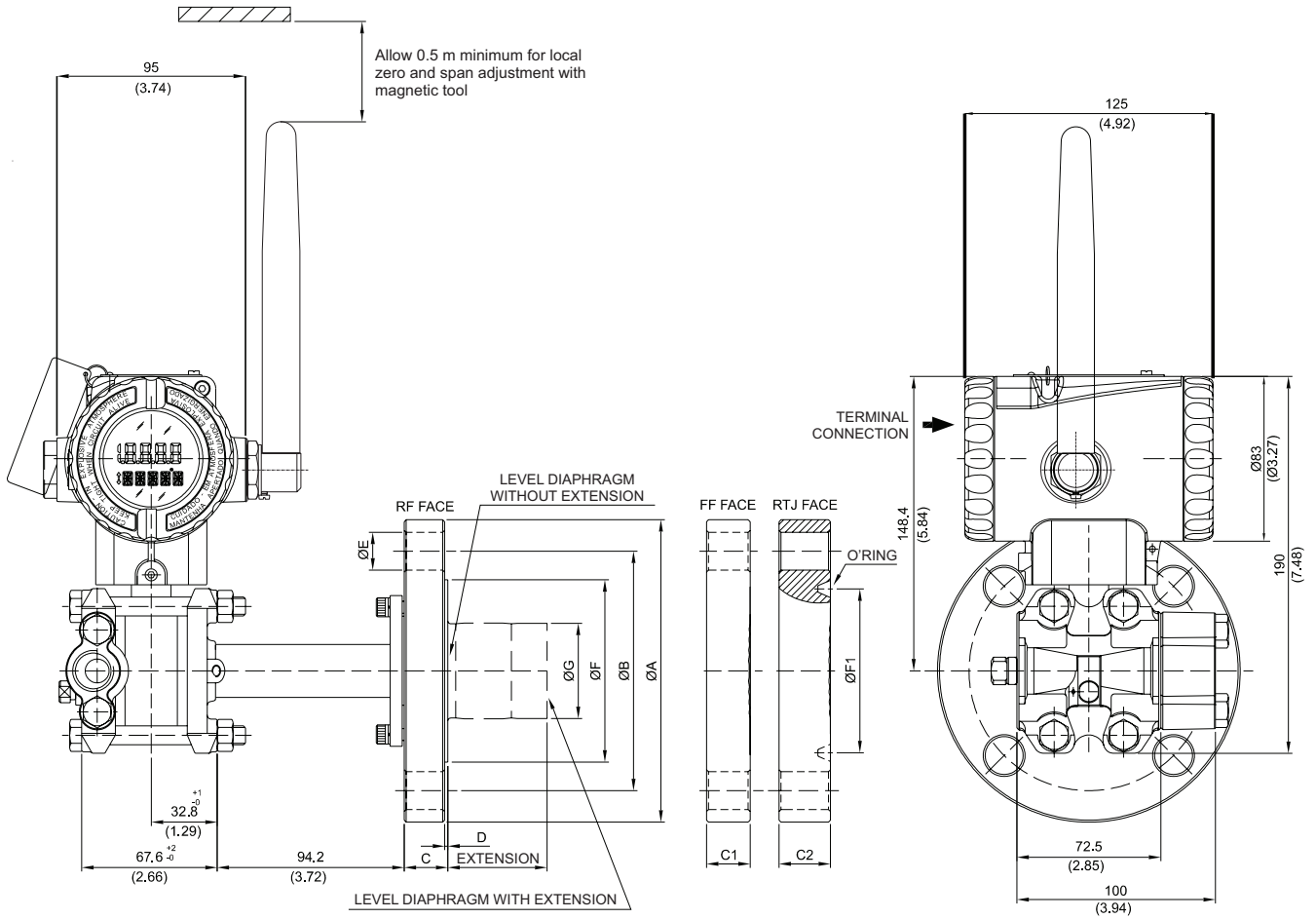

Notes:
 - Extension length (mm): 0, 50, 100, 150 or 200
 - Dimensions are mm (in)

ANSI-B 16.5 Dimensions													
DN	Class	A	B	C (RF)	C1 (FF)	C2 (RTJ)	D (RF)	E	F (RF)	F1 (RTJ)	RTJ O-RING	G	Holes
1.1/2"	150	127 (5)	98.6 (3.88)	20 (0.78)	19 (0.75)	24.4 (0.96)	1.6 (0.06)	16 (0.63)	73.2 (2.88)	65.1 (2.56)	R19	40 (1.57)	4
	300	155.4 (6.12)	114.3 (4.5)	21 (0.83)	21 (0.83)	27.4 (1.07)	1.6 (0.06)	22 (0.87)	73.2 (2.88)	68.3 (2.68)	R20	40 (1.57)	4
	600	155.4 (6.12)	114.3 (4.5)	29.3 (1.15)	29.3 (1.15)	29.3 (1.15)	6.4 (0.25)	22 (0.87)	73.2 (2.88)	68.3 (2.68)	R20	40 (1.57)	4
2"	150	152.4 (6)	120.7 (4.75)	22 (0.87)	20 (0.78)	25.9 (1.02)	1.6 (0.06)	19 (0.75)	91.9 (3.62)	82.6 (3.25)	R22	48 (1.89)	4
	300	165.1 (6.5)	127 (5)	22.8 (0.9)	22.8 (0.89)	30.8 (1.21)	1.6 (0.06)	19 (0.75)	91.9 (3.62)	82.6 (3.25)	R23	48 (1.89)	8
	600	165.1 (6.5)	127 (5)	32.3 (1.27)	32.3 (1.27)	32.3 (1.27)	6.4 (0.25)	19 (0.75)	91.9 (3.62)	82.6 (3.25)	R23	48 (1.89)	8
3"	150	190.5 (7.5)	152.4 (6)	24.4 (0.96)	24.4 (0.96)	30.7 (1.21)	1.6 (0.06)	19 (0.75)	127 (5)	114.3 (4.50)	R29	73 (2.87)	4
	300	209.5 (8.25)	168.1 (6.62)	29 (1.14)	29 (1.14)	36.9 (1.45)	1.6 (0.06)	22 (0.87)	127 (5)	123.8 (4.87)	R31	73 (2.87)	8
	600	209.5 (8.25)	168.1 (6.62)	38.7 (1.52)	38.7 (1.52)	40.2 (1.58)	6.4 (0.25)	22 (0.87)	127 (5)	123.8 (4.87)	R31	73 (2.87)	8
4"	150	228.6 (9)	190.5 (7.5)	24.4 (0.96)	24.4 (0.96)	30.7 (1.21)	1.6 (0.06)	19 (0.75)	158 (6.22)	149.2 (5.87)	R36	96 (3.78)	8
	300	254 (10)	200 (7.87)	32.2 (1.27)	32.2 (1.27)	40.2 (1.58)	1.6 (0.06)	22 (0.87)	158 (6.22)	149.2 (5.87)	R37	96 (3.78)	8
	600	273 (10.75)	215.9 (8.5)	45 (1.77)	45 (1.77)	46.5 (1.83)	6.4 (0.25)	25 (1)	158 (6.22)	149.2 (5.87)	R37	96 (3.78)	8

EN 1092-1 Dimensions												
DN	PN	A	B	C (RF)	C1 (FF)	D	E	F (RF)	G	Holes		
DN40	10/40	150 (5.9)	110 (4.33)	20 (0.78)	20 (0.78)	3 (0.12)	18 (0.71)	88 (3.46)	40 (1.57)	4		
DN50	10/40	165 (6.5)	125 (4.92)	20 (0.78)	22 (0.86)	3 (0.12)	18 (0.71)	102 (4.01)	48 (1.89)	4		
DN80	10/40	200 (7.87)	160 (6.3)	24 (0.95)	24 (0.94)	3 (0.12)	18 (0.71)	138 (5.43)	73 (2.87)	8		
DN100	10/16	220 (8.67)	180 (7.08)	20 (0.78)		3 (0.12)	18 (0.71)	158 (6.22)	96 (3.78)	8		
	25/40	235 (9.25)	190 (7.5)	24 (0.95)		3 (0.12)	22 (0.87)	162 (6.38)	96 (3.78)	8		

JIS B 2202 Dimensions												
DN	Class	A	B	C	D	E	F (RF)	G	Holes			
40A	20K	140 (5.5)	105 (4.13)	26 (1.02)	2 (0.08)	19 (0.75)	81 (3.2)	40 (1.57)	4			
50A	10K	155 (6.1)	120 (4.72)	26 (1.02)	2 (0.08)	19 (0.75)	96 (3.78)	48 (1.89)	4			
	40K	165 (6.5)	130 (5.12)	26 (1.02)	2 (0.08)	19 (0.75)	105 (4.13)	48 (1.89)	8			
80A	10K	185 (7.28)	150 (5.9)	26 (1.02)	2 (0.08)	19 (0.75)	126 (4.96)	73 (2.87)	8			
	20K	200 (7.87)	160 (6.3)	26 (1.02)	2 (0.08)	19 (0.75)	132 (5.2)	73 (2.87)	8			
100A	10K	210 (8.27)	175 (6.89)	26 (1.02)	2 (0.08)	19 (0.75)	151 (5.95)	96 (3.78)	8			

LD400L - Flanged Pressure Transmitter with Slip-on Flange

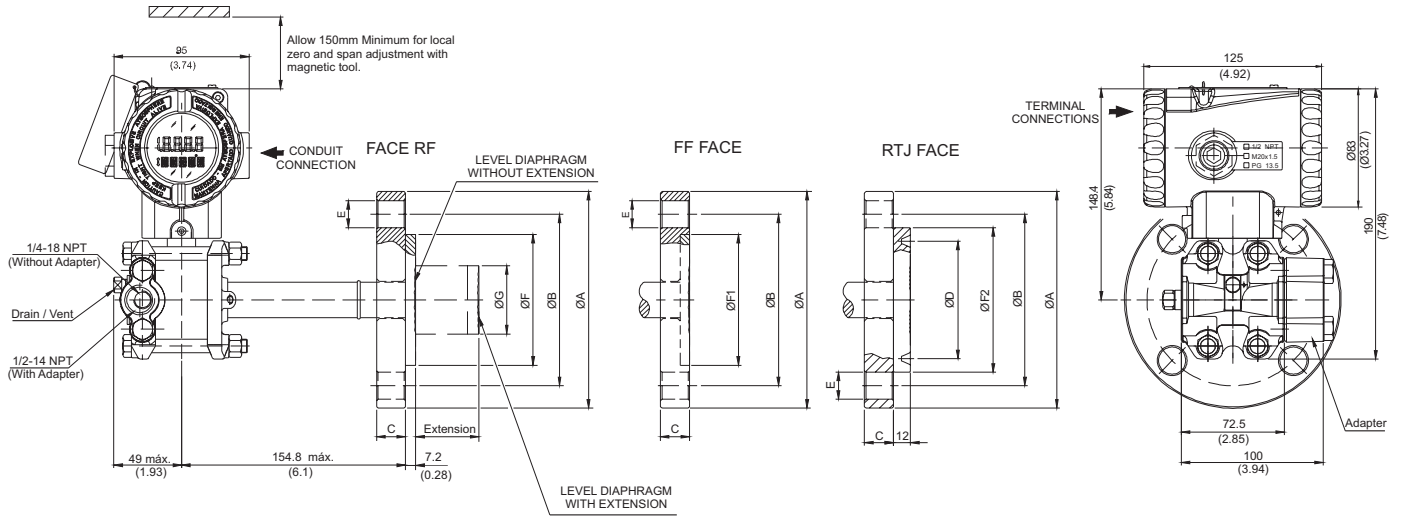

ANSI-B 16.5 DIMENSIONS												
DN	CLASS	A	B	C	D	E	F (RF)	F1 (FF)	F2 (RTJ)	G	HOLES	
1"	150	108 (4.25)	79.4 (3.16)	14.3 (0.56)	-	16 (0.63)	50.8 (2)	50.8 (2)	-	-	4	
	300/600	124 (4.88)	88.9 (3.5)	17.5 (0.69)	-	19 (0.75)	50.8 (2)	50.8 (2)	-	-	4	
1 1/2"	150	127 (5)	98.4 (3.87)	17.5 (0.69)	-	16 (0.63)	73 (2.87)	73 (2.87)	-	40 (1.57)	4	
	300/600	156 (6.14)	114.3 (4.5)	22.2 (0.87)	-	22 (0.87)	73 (2.87)	73 (2.87)	-	40 (1.57)	4	
2"	150	152.4 (6)	120.7 (4.75)	17.5 (0.69)	82.6 (3.25)	19 (0.75)	92 (3.62)	92 (3.62)	101.6 (4.00)	48 (1.89)	4	
	300	165.1 (6.5)	127 (5)	20.7 (0.8)	82.6 (3.25)	19 (0.75)	92 (3.62)	92 (3.62)	107.9 (4.25)	48 (1.89)	8	
	600	165.1 (6.5)	127 (5)	25.4 (1)	82.6 (3.25)	19 (0.75)	92 (3.62)	92 (3.62)	107.9 (4.25)	48 (1.89)	8	
3"	150	190.5 (7.5)	152.4 (6)	22.3 (0.87)	114.3 (4.50)	19 (0.75)	127 (5)	127 (5)	133.4 (5.25)	73 (2.87)	4	
	300	209.5 (8.25)	168.1 (6.62)	27 (1.06)	123.8 (4.87)	22 (0.87)	127 (5)	127 (5)	146.1 (5.75)	73 (2.87)	8	
	600	209.5 (8.25)	168.1 (6.62)	31.8 (1.25)	123.8 (4.87)	22 (0.87)	127 (5)	127 (5)	146.1 (5.75)	73 (2.87)	8	
4"	150	228.6 (9)	190.5 (7.5)	22.3 (0.87)	149.2 (5.87)	19 (0.75)	158 (6.22)	158 (6.22)	171.5 (6.75)	89 (3.5)	8	
	300	254 (10)	200 (7.87)	30.2 (1.18)	149.2 (5.87)	22 (0.87)	158 (6.22)	158 (6.22)	174.6 (6.87)	89 (3.5)	8	
	600	273 (10.75)	215.9 (8.5)	38.1 (1.5)	149.2 (5.87)	25 (1)	158 (6.22)	158 (6.22)	174.6 (6.87)	89 (3.5)	8	

EN 1092-1 / DIN2501 DIMENSIONS- RF/ FF									
DN	PN	A	B	C	E	F	G	HOLES	
25	10/40	115 (4.53)	85 (3.35)	18 (0.71)	14 (0.55)	68 (2.68)	-	4	
40	10/40	150 (5.91)	110 (4.33)	18 (0.71)	18 (0.71)	88 (3.46)	73 (2.87)	4	
50	10/40	165 (6.50)	125 (4.92)	20 (0.78)	18 (0.71)	102 (4.01)	48 (1.89)	4	
80	10/40	200 (7.87)	160 (6.30)	24 (0.95)	18 (0.71)	138 (5.43)	73 (2.87)	8	
	10/16	220 (8.67)	180 (7.08)	20 (0.78)	18 (0.71)	158 (6.22)	89 (3.5)	8	
100	25/40	235 (9.25)	190 (7.50)	24 (0.95)	22 (0.87)	162 (6.38)	89 (3.5)	8	

NOTES:
 - Extension Length mm (in): 0, 50 (1.96) 100 (3.93), 150 (5.9) ou 200 (7.87)
 - Dimensions are mm (in)

LD400L - Wireless Flanged Pressure Transmitter with Slip-on Flange Wireless

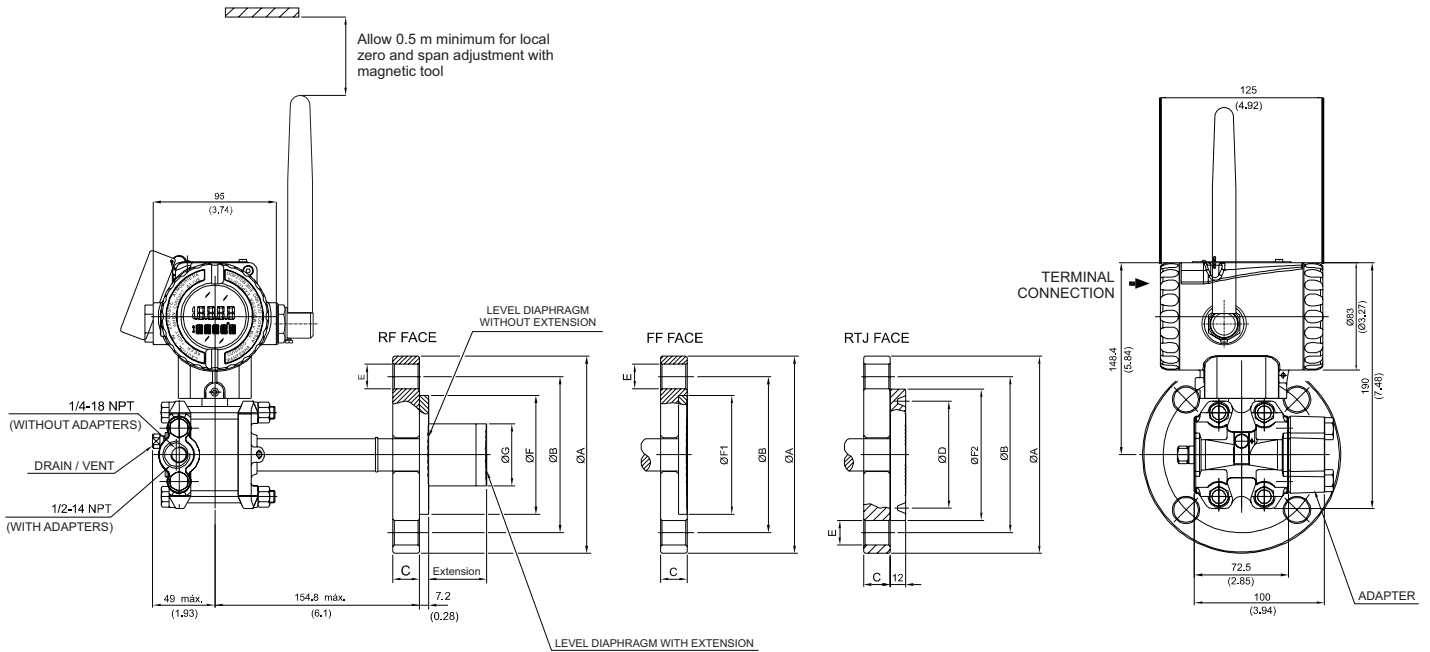

ANSI-B 16.5 DIMENSIONS

DN	CLASS	A	B	C	D	E	F (RF)	F1 (FF)	F2 (RTJ)	G	Holes
2"	150	152.4 (6)	120.7 (4.75)	17.5 (0.69)	82.6 (3.25)	19 (0.75)	92 (3.62)	92 (3.62)	101.6 (4.00)	48 (1.89)	4
	300	165.1 (6.5)	127 (5)	20.7 (0.8)	82.6 (3.25)	19 (0.75)	92 (3.62)	92 (3.62)	107.9 (4.25)	48 (1.89)	8
	600	165.1 (6.5)	127 (5)	25.4 (1)	82.6 (3.25)	19 (0.75)	92 (3.62)	92 (3.62)	107.9 (4.25)	48 (1.89)	8
3"	150	190.5 (7.5)	152.4 (6)	22.3 (0.87)	114.3 (4.50)	19 (0.75)	127 (5)	127 (5)	133.4 (5.25)	73 (2.87)	4
	300	209.5 (8.25)	168.1 (6.62)	27 (1.06)	123.8 (4.87)	22 (0.87)	127 (5)	127 (5)	146.1 (5.75)	73 (2.87)	8
	600	209.5 (8.25)	168.1 (6.62)	31.8 (1.25)	123.8 (4.87)	22 (0.87)	127 (5)	127 (5)	146.1 (5.75)	73 (2.87)	8
4"	150	228.6 (9)	190.5 (7.5)	22.3 (0.87)	149.2 (5.87)	19 (0.75)	158 (6.22)	158 (6.22)	171.5 (6.75)	89 (3.5)	8
	300	254 (10)	200 (7.87)	30.2 (1.18)	149.2 (5.87)	22 (0.87)	158 (6.22)	158 (6.22)	174.6 (6.87)	89 (3.5)	8
	600	273 (10.75)	215.9 (8.5)	38.1 (1.5)	149.2 (5.87)	25 (1)	158 (6.22)	158 (6.22)	174.6 (6.87)	89 (3.5)	8

EN 1092-1 / DIN2501 DIMENSIONS- RF/ FF

DN	PN	A	B	C	E	F	G	Holes
50	10/40	165 (6.50)	125 (4.92)	20 (0.78)	18 (0.71)	102 (4.01)	48 (1.89)	4
80	10/40	200 (7.87)	160 (6.30)	24 (0.95)	18 (0.71)	138 (5.43)	73 (2.87)	8
100	10/16	220 (8.67)	180 (7.08)	20 (0.78)	18 (0.71)	158 (6.22)	89 (3.5)	8
	25/40	235 (9.25)	190 (7.50)	24 (0.95)	22 (0.87)	162 (6.38)	89 (3.5)	8

Notes:
 - Extension length mm (in): 0, 50 (1.96), 100 (3.93), 150 (5.9) or 200 (7.87)
 - Dimensions are mm (in)

LD400L - Flanged Pressure Transmitter with Housing

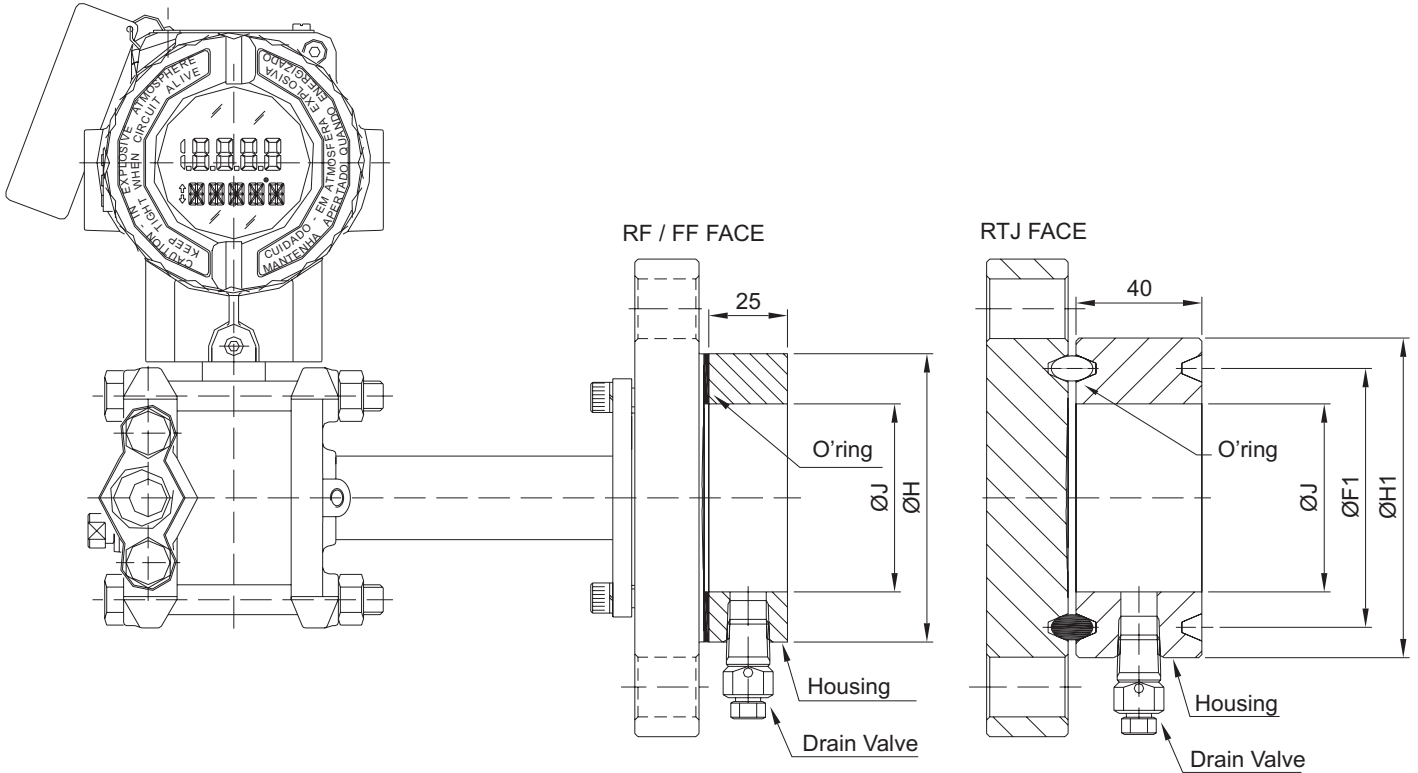

DIMENSIONS IN mm (")

ANSI-B 16.5 DIMENSIONS			
DN	CLASS	H	J
1.1/2"	ALL	73.2 (2.88)	48 (1.89)
2"		91.9 (3.62)	60 (2.36)
3"		127 (5.00)	89 (3.50)
4"		158 (6.22)	115 (4.53)
FORM D DIMENSIONS DIN EN1092-1/ DIN2501/2526			
DN	PN	H	J
40	ALL	88 (3.46)	48 (1.89)
50		102 (4.02)	60 (2.36)
80		138 (5.43)	89 (3.50)
100		158 (6.22)	115 (4.53)
JIS B 2202 DIMENSIONS			
DN	CLASS	H	J
40A	20K	81 (3.19)	48 (1.89)
50A	10K	96 (3.78)	60 (1.36)
	40K	105 (4.13)	60 (1.36)
80A	10K	126 (4.96)	89 (3.50)
	20K	132 (5.20)	89 (3.50)
100A	10K	151 (5.94)	115 (4.53)

DIMENSIONS IN mm (")

ANSI-B 16.5 DIMENSIONS - RTJ FACE					
DN	CLASSE	F1	O'RING	H1	J
1.1/2"	150	65.1 (2.56)	R19	82.5 (3.25)	48 (1.89)
	300	68.3 (2.69)	R20	90.5 (3.56)	48 (1.89)
	600	68.3 (2.69)	R20	90.5 (3.56)	48 (1.89)
	1500	68.3 (2.69)	R20	92 (3.62)	48 (1.89)
	2500	82.6 (3.25)	R23	114 (4.50)	48 (1.89)
2"	150	82.6 (3.25)	R22	102 (4.00)	60 (2.36)
	300	82.6 (3.25)	R23	108 (4.25)	60 (2.36)
	600	82.6 (3.25)	R23	108 (4.25)	60 (2.36)
	1500	95.3 (3.75)	R24	124 (4.88)	60 (2.36)
	2500	101.6 (4.00)	R26	133 (5.25)	60 (2.36)
3"	150	114.3 (4.50)	R29	133 (5.25)	89 (3.50)
	300	123.8 (4.87)	R31	146 (5.75)	89 (3.50)
	600	123.8 (4.87)	R31	146 (5.75)	89 (3.50)
4"	150	149.2 (5.87)	R36	171 (6.75)	115 (4.53)
	300	149.2 (5.87)	R37	175 (6.88)	115 (4.53)
	600	149.2 (5.87)	R37	175 (6.88)	115 (4.53)

LD400L - Wireless Flanged Pressure Transmitter with Housing Wireless

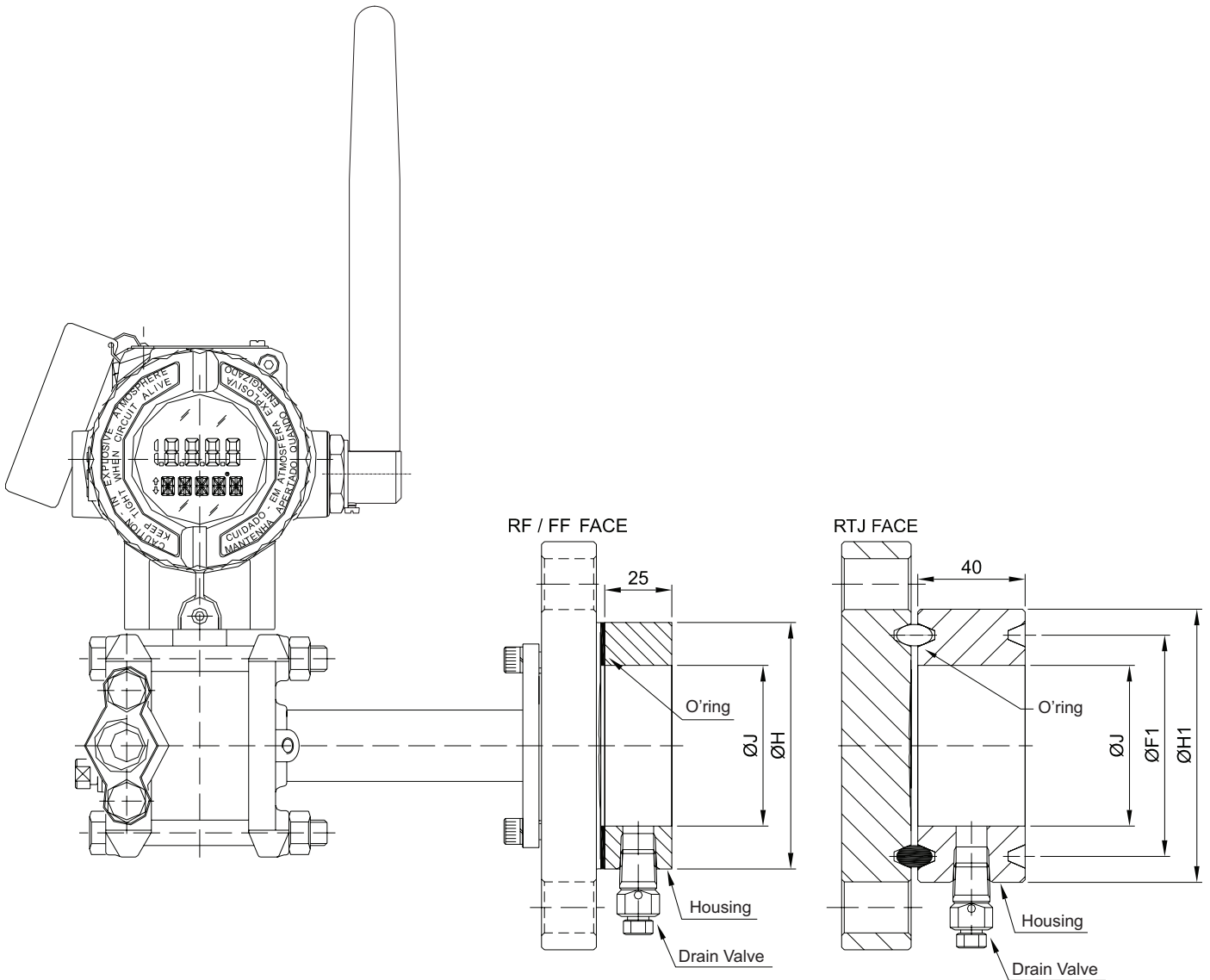

DIMENSIONS IN mm (")

ANSI-B 16.5 DIMENSIONS			
DN	CLASS	H	J
1.1/2"	ALL	73.2 (2.88)	48 (1.89)
2"		91.9 (3.62)	60 (2.36)
3"		127 (5.00)	89 (3.50)
4"		158 (6.22)	115 (4.53)
FORM D DIMENSIONS DIN EN1092-1/ DIN2501/2526			
DN	PN	H	J
40	ALL	88 (3.46)	48 (1.89)
50		102 (4.02)	60 (2.36)
80		138 (5.43)	89 (3.50)
100		158 (6.22)	115 (4.53)
JIS B 2202 DIMENSIONS			
DN	CLASS	H	J
40A	20K	81 (3.19)	48 (1.89)
	10K	96 (3.78)	60 (1.36)
50A	40K	105 (4.13)	60 (1.36)
	10K	126 (4.96)	89 (3.50)
80A	20K	132 (5.20)	89 (3.50)
	10K	151 (5.94)	115 (4.53)

DIMENSIONS IN mm (")

ANSI-B 16.5 DIMENSIONS - FACE RTJ					
DN	CLASS	F1	O-RING	H1	J
1.1/2"	150	65.1 (2.56)	R19	82.5 (3.25)	48 (1.89)
	300	68.3 (2.69)	R20	90.5 (3.56)	48 (1.89)
	600	68.3 (2.69)	R20	90.5 (3.56)	48 (1.89)
	1500	68.3 (2.69)	R20	92 (3.62)	48 (1.89)
	2500	82.6 (3.25)	R23	114 (4.50)	48 (1.89)
2"	150	82.6 (3.25)	R22	102 (4.00)	60 (2.36)
	300	82.6 (3.25)	R23	108 (4.25)	60 (2.36)
	600	82.6 (3.25)	R23	108 (4.25)	60 (2.36)
	1500	95.3 (3.75)	R24	124 (4.88)	60 (2.36)
	2500	101.6 (4.00)	R26	133 (5.25)	60 (2.36)
3"	150	114.3 (4.50)	R29	133 (5.25)	89 (3.50)
	300	123.8 (4.87)	R31	146 (5.75)	89 (3.50)
	600	123.8 (4.87)	R31	146 (5.75)	89 (3.50)
4"	150	149.2 (5.87)	R36	171 (6.75)	115 (4.53)
	300	149.2 (5.87)	R37	175 (6.88)	115 (4.53)
	600	149.2 (5.87)	R37	175 (6.88)	115 (4.53)

LD400S - Sanitary Transmitter With Extension

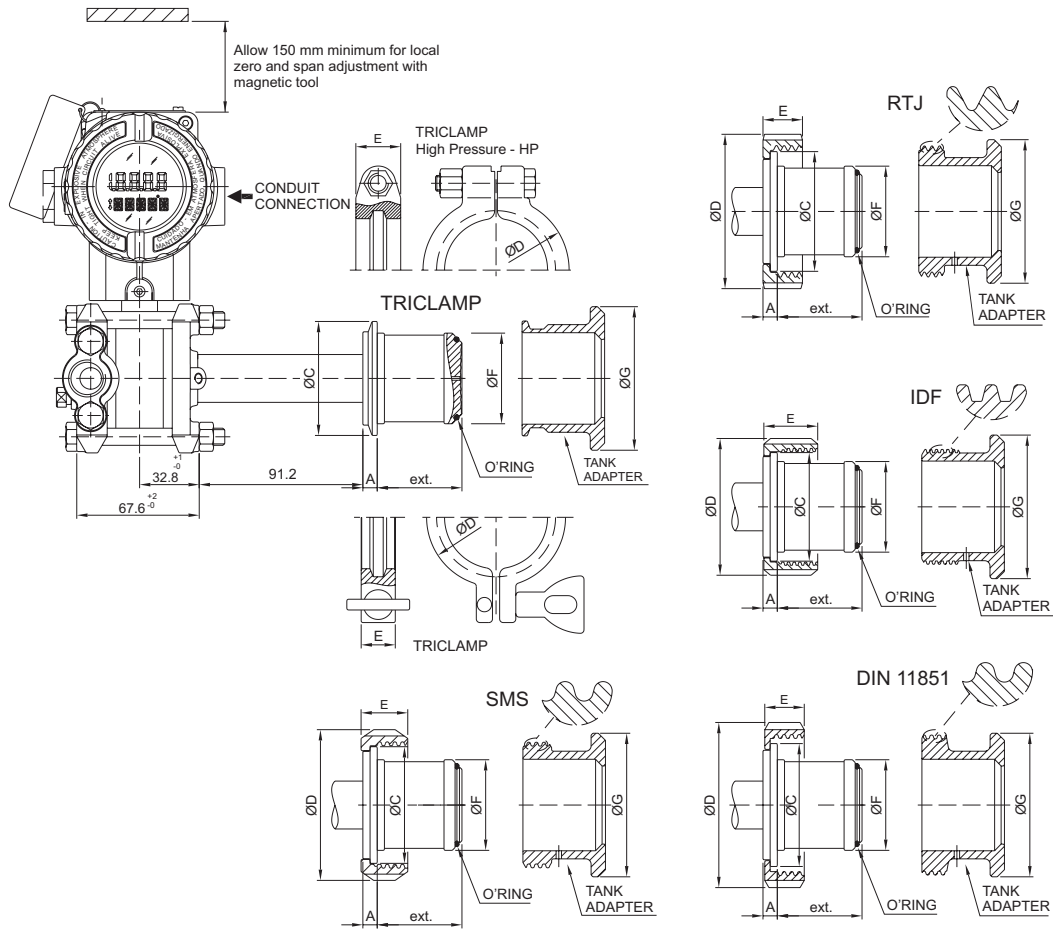

LD400S							
CONNECTION WITH EXTENSION	Dimensions in mm (")						
	A	ØC	ØD	E	ØF	ØG	EXT.
Tri-Clamp DN50	8 (0.315)	63.5 (2.5)	76.5 (3.01)	18 (0.71)	52 (2.05)	80 (3.15)	47.2 (1.86)
Tri-Clamp DN50H P	8 (0.315)	63.5 (2.5)	81 (3.19)	25 (0.98)	52 (2.05)	80 (3.15)	47.2 (1.86)
Tri-Clamp-2 "	8 (0.315)	63.5 (2.5)	76.5 (3.01)	18 (0.71)	52 (2.05)	80 (3.15)	47.2 (1.86)
Tri-Clamp-2 "H P	8 (0.315)	63.5 (2.5)	81 (3.19)	25 (0.98)	52 (2.05)	80 (3.15)	47.2 (1.86)
Tri-Clamp-3 "	8 (0.315)	91 (3.58)	110 (4.33)	18 (0.71)	72.5 (2.85)	100 (3.94)	50 (1.96)
Tri-Clamp-3 "H P	8 (0.315)	91 (3.58)	115 (4.53)	25 (0.98)	72.5 (2.85)	100 (3.94)	50 (1.96)
Threaded DN25-D IN 11851	6 (0.24)	47.5 (1.87)	63 (2.48)	21 (0.83)	43.2 (1.7)	80 (3.15)	26.3 (1.03)
Threaded DN40-D IN 11851	8 (0.315)	56 (2.2)	78 (3.07)	21 (0.83)	52 (2.05)	80 (3.15)	47.2 (1.86)
Threaded DN50-D IN 11851	8 (0.315)	68.5 (2.7)	92 (3.62)	22 (0.86)	52 (2.05)	80 (3.15)	47.2 (1.86)
Threaded DN80-D IN 11851	8 (0.315)	100 (3.94)	127 (5)	29 (1.14)	72.5 (2.85)	100 (3.94)	50 (1.96)
Threaded SMS-2 "	8 (0.315)	65 (2.56)	84 (3.3)	26 (1.02)	52 (2.05)	80 (3.15)	47.2 (1.86)
Threaded SMS-3 "	8 (0.315)	93 (3.66)	113 (4.45)	32 (1.26)	72.5 (2.85)	100 (3.94)	50 (1.96)
Threaded RJT- 2"	8 (0.315)	66.7 (2.63)	86 (3.38)	22 (0.86)	52 (2.05)	80 (3.15)	47.2 (1.86)
Threaded RJT- 3"	8 (0.315)	92 (3.62)	112 (4.41)	22.2 (0.87)	72.5 (2.85)	100 (3.94)	50 (1.96)
Threaded IDF-2 "	8 (0.315)	60.5 (2.38)	76.2 (3)	30 (1.18)	52 (2.05)	80 (3.15)	47.2 (1.86)
Threaded IDF-3 "	8 (0.315)	87.5 (3.44)	101.6 (4)	30 (1.18)	72.5 (2.85)	100 (3.94)	50 (1.96)

LD400S - Wireless Sanitary Transmitter With Extension Wireless

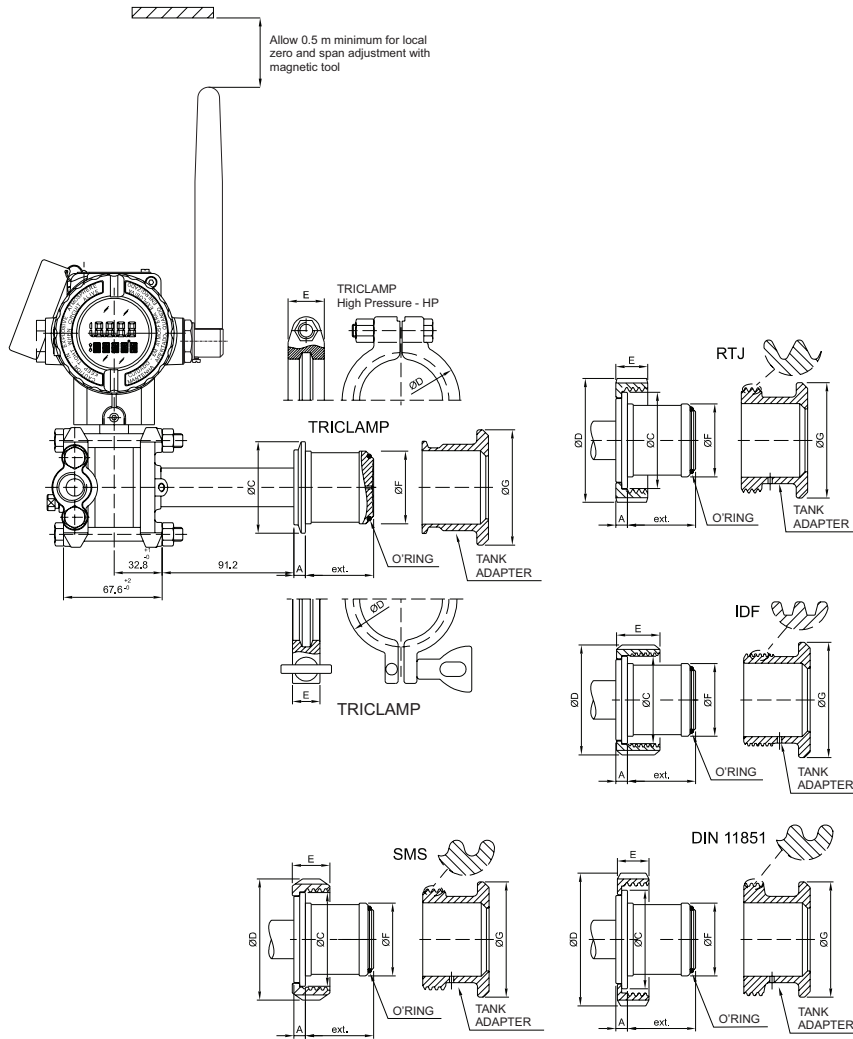

LD400S							
CONNECTION WITH EXTENSION	Dimensions in mm (")						
	A	ØC	ØD	E	ØF	ØG	EXT.
Tri-Clamp DN50	8 (0.315)	63.5 (2.5)	76.5 (3.01)	18 (0.71)	52 (2.05)	80 (3.15)	47.2 (1.86)
Tri-Clamp DN50H P	8 (0.315)	63.5 (2.5)	81 (3.19)	25 (0.98)	52 (2.05)	80 (3.15)	47.2 (1.86)
Tri-Clamp-2 "	8 (0.315)	63.5 (2.5)	76.5 (3.01)	18 (0.71)	52 (2.05)	80 (3.15)	47.2 (1.86)
Tri-Clamp-2 "H P	8 (0.315)	63.5 (2.5)	81 (3.19)	25 (0.98)	52 (2.05)	80 (3.15)	47.2 (1.86)
Tri-Clamp-3 "	8 (0.315)	91 (3.58)	110 (4.33)	18 (0.71)	72.5 (2.85)	100 (3.94)	50 (1.96)
Tri-Clamp-3 "H P	8 (0.315)	91 (3.58)	115 (4.53)	25 (0.98)	72.5 (2.85)	100 (3.94)	50 (1.96)
Threaded DN25-D IN 11851	6 (0.24)	47.5 (1.87)	63 (2.48)	21 (0.83)	43.2 (1.7)	80 (3.15)	26.3 (1.03)
Threaded DN40-D IN 11851	8 (0.315)	56 (2.2)	78 (3.07)	21 (0.83)	52 (2.05)	80 (3.15)	47.2 (1.86)
Threaded DN50-D IN 11851	8 (0.315)	68.5 (2.7)	92 (3.62)	22 (0.86)	52 (2.05)	80 (3.15)	47.2 (1.86)
Threaded DN80-D IN 11851	8 (0.315)	100 (3.94)	127 (5)	29 (1.14)	72.5 (2.85)	100 (3.94)	50 (1.96)
Threaded SMS-2 "	8 (0.315)	65 (2.56)	84 (3.3)	26 (1.02)	52 (2.05)	80 (3.15)	47.2 (1.86)
Threaded SMS-3 "	8 (0.315)	93 (3.66)	113 (4.45)	32 (1.26)	72.5 (2.85)	100 (3.94)	50 (1.96)
Threaded RJT- 2"	8 (0.315)	66.7 (2.63)	86 (3.38)	22 (0.86)	52 (2.05)	80 (3.15)	47.2 (1.86)
Threaded RJT- 3"	8 (0.315)	92 (3.62)	112 (4.41)	22.2 (0.87)	72.5 (2.85)	100 (3.94)	50 (1.96)
Threaded IDF-2 "	8 (0.315)	60.5 (2.38)	76.2 (3)	30 (1.18)	52 (2.05)	80 (3.15)	47.2 (1.86)
Threaded IDF-3 "	8 (0.315)	87.5 (3.44)	101.6 (4)	30 (1.18)	72.5 (2.85)	100 (3.94)	50 (1.96)

LD400S - Sanitary Transmitter Without Extension

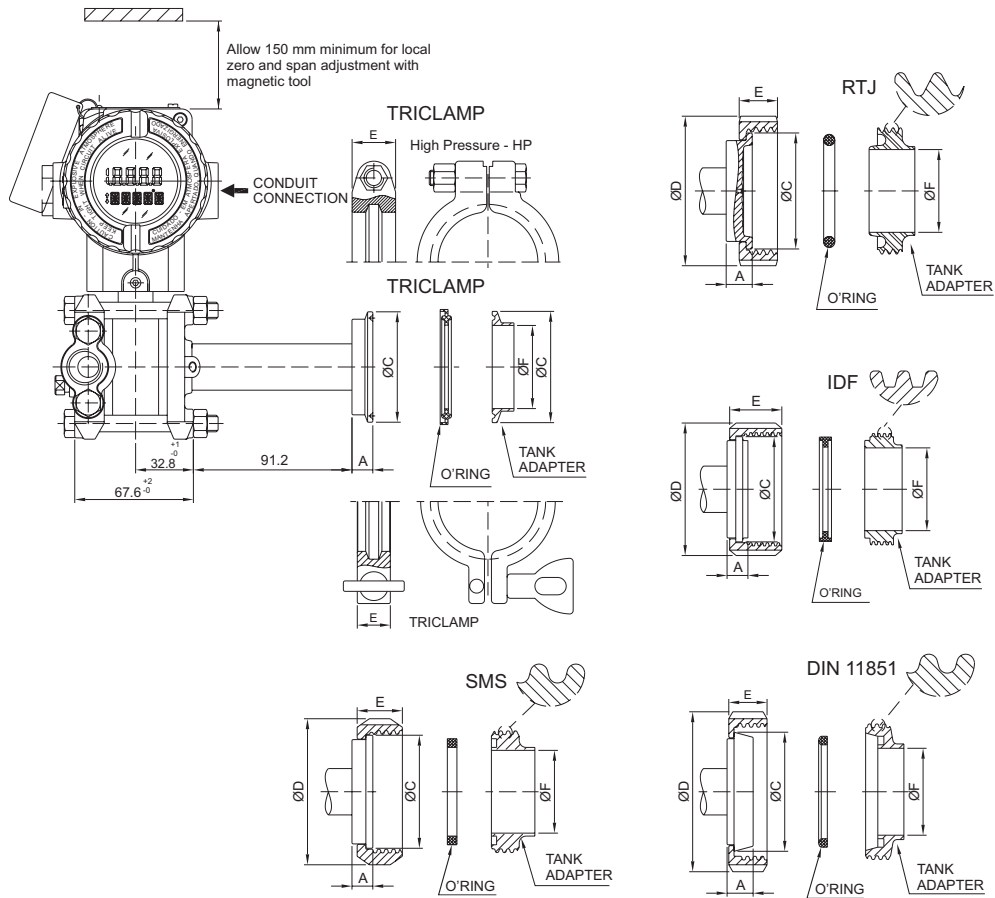

LD400S							
CONNECTION WITHOUT EXTENSION	Dimensions in mm (")						
	A	ØC	ØD	E	ØF	ØG	EXT.
Tri-Clamp DN50	8 (0.315)	63.5 (2.5)	76.5 (3.01)	18 (0.71)	47.5 (1.87)	---	---
Tri-Clamp-11 1/2"	12 (0.47)	50 (1.96)	61 (2.4)	18 (0.71)	35 (1.38)	---	---
Tri-Clamp-11 1/2" H P	12 (0.47)	50 (1.96)	66 (2.59)	25 (0.98)	35 (1.38)	---	---
Tri-Clamp-2 "	12 (0.47)	63.5 (2.5)	76.5 (3.01)	18 (0.71)	47.6 (1.87)	---	---
Tri-Clamp-2 " H P	12 (0.47)	63.5 (2.5)	81 (3.19)	25 (0.98)	47.6 (1.87)	---	---
Tri-Clamp-3 "	12 (0.47)	91 (3.58)	110 (4.33)	18 (0.71)	72 (2.83)	---	---
Tri-Clamp-3 " H P	12 (0.47)	91 (3.58)	115 (4.53)	25 (0.98)	72 (2.83)	---	---
Threaded DN40-D IN 11851	13 (0.51)	56 (2.2)	78 (3.07)	21 (0.83)	38 (1.5)	---	---
Threaded DN50-D IN 11851	15 (0.59)	68.5 (2.7)	92 (3.62)	22 (0.86)	50 (1.96)	---	---
Threaded DN80-D IN 11851	16 (0.63)	100 (3.94)	127 (5)	29 (1.14)	81 (3.19)	---	---
Threaded SMS -11 1/2"	12 (0.47)	55 (2.16)	74 (2.91)	25 (0.98)	35 (1.38)	---	---
Threaded SMS -2 "	12 (0.47)	65 (2.56)	84 (3.3)	26 (1.02)	48.6 (1.91)	---	---
Threaded SMS -3 "	12 (0.47)	93 (3.66)	113 (4.45)	32 (1.26)	73 (2.87)	---	---
Threaded RJT -2 "	15 (0.59)	66.7 (2.63)	86 (3.38)	22 (0.86)	47.6 (1.87)	---	---
Threaded RJT -3 "	15 (0.59)	92 (3.62)	112 (4.41)	22.2 (0.87)	73 (2.87)	---	---
Threaded IDF- 2"	12 (0.47)	60.5 (2.38)	76 (2.99)	30 (1.18)	47.6 (1.87)	---	---
Threaded IDF- 3"	12 (0.47)	87.5 (3.44)	101.6 (4)	30 (1.18)	73 (2.87)	---	---

LD400S - Wireless Sanitary Transmitter Without Extension Wireless

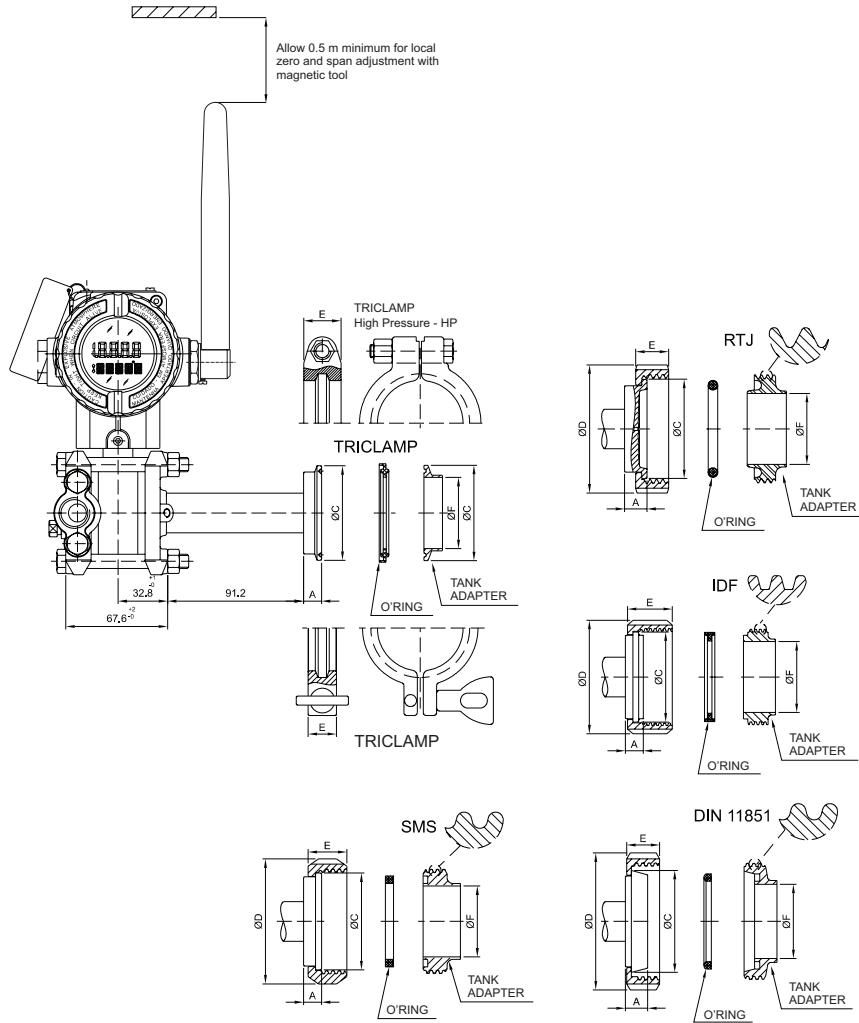

LD400S							
CONNECTION WITHOUT EXTENSION	Dimensions in mm (")						
	A	ØC	ØD	E	ØF	ØG	EXT.
Tri-Clamp DN50	8 (0.315)	63.5 (2.5)	76.5 (3.01)	18 (0.71)	47.5 (1.87)	--	--
Tri-Clamp-11 1/2"	12 (0.47)	50 (1.96)	61 (2.4)	18 (0.71)	35 (1.38)	--	--
Tri-Clamp-11 1/2"H P	12 (0.47)	50 (1.96)	66 (2.59)	25 (0.98)	35 (1.38)	--	--
Tri-Clamp-2 "	12 (0.47)	63.5 (2.5)	76.5 (3.01)	18 (0.71)	47.6 (1.87)	--	--
Tri-Clamp-2 "H P	12 (0.47)	63.5 (2.5)	81 (3.19)	25 (0.98)	47.6 (1.87)	--	--
Tri-Clamp-3 "	12 (0.47)	91 (3.58)	110 (4.33)	18 (0.71)	72 (2.83)	--	--
Tri-Clamp-3 "H P	12 (0.47)	91 (3.58)	115 (4.53)	25 (0.98)	72 (2.83)	--	--
Threaded DN40-DIN 11851	13 (0.51)	56 (2.2)	78 (3.07)	21 (0.83)	38 (1.5)	--	--
Threaded DN50-DIN 11851	15 (0.59)	68.5 (2.7)	92 (3.62)	22 (0.86)	50 (1.96)	--	--
Threaded DN80-DIN 11851	16 (0.63)	100 (3.94)	127 (5)	29 (1.14)	81 (3.19)	--	--
Threaded SMS -11 1/2"	12 (0.47)	55 (2.16)	74 (2.91)	25 (0.98)	35 (1.38)	--	--
Threaded SMS -2 "	12 (0.47)	65 (2.56)	84 (3.3)	26 (1.02)	48.6 (1.91)	--	--
Threaded SMS -3 "	12 (0.47)	93 (3.66)	113 (4.45)	32 (1.26)	73 (2.87)	--	--
Threaded RJT -2 "	15 (0.59)	66.7 (2.63)	86 (3.38)	22 (0.86)	47.6 (1.87)	--	--
Threaded RJT -3 "	15 (0.59)	92 (3.62)	112 (4.41)	22.2 (0.87)	73 (2.87)	--	--
Threaded IDF- 2"	12 (0.47)	60.5 (2.38)	76 (2.99)	30 (1.18)	47.6 (1.87)	--	--
Threaded IDF- 3"	12 (0.47)	87.5 (3.44)	101.6 (4)	30 (1.18)	73 (2.87)	--	--

LD400G - Gage Inline Pressure Transmitter

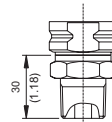
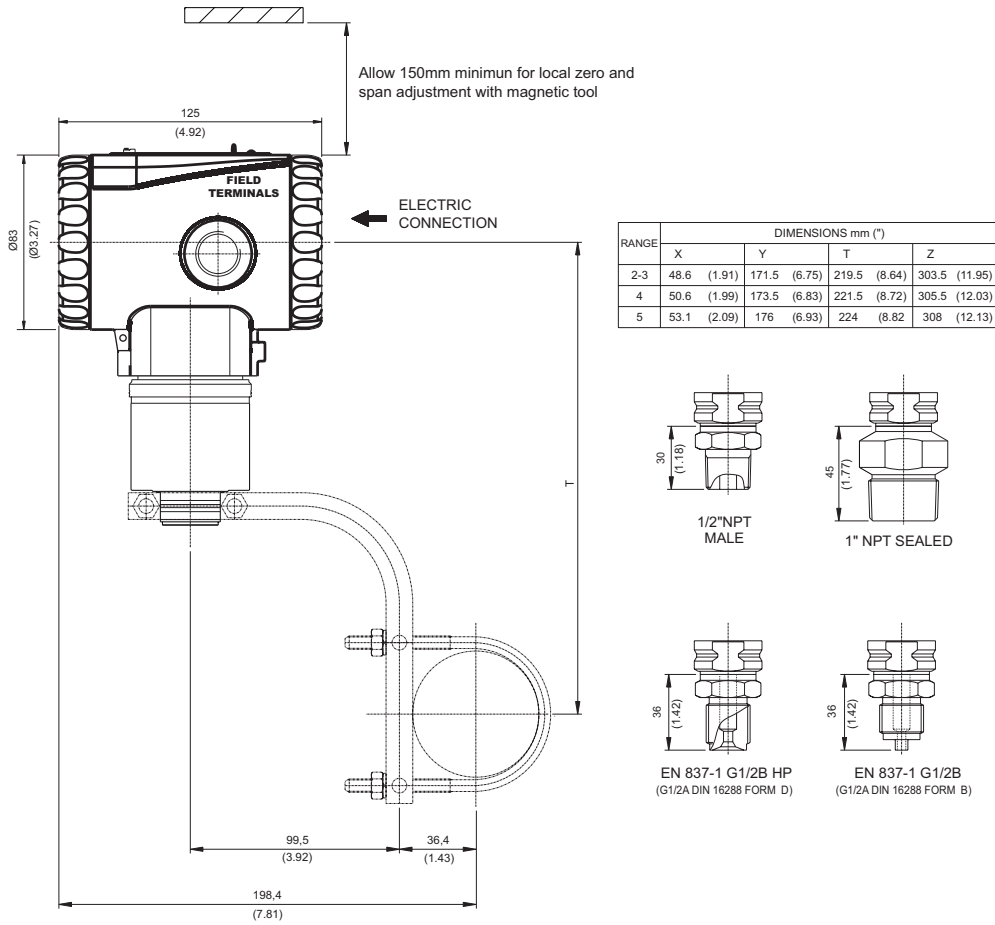

1/2" NPT MALE

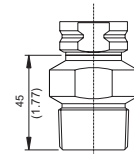

1" NPT SEALED

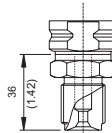

EN 837-1 G1/2B HP (G1/2A DIN 16288 FORM D)

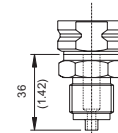

EN 837-1 G1/2B (G1/2A DIN 16288 FORM B)

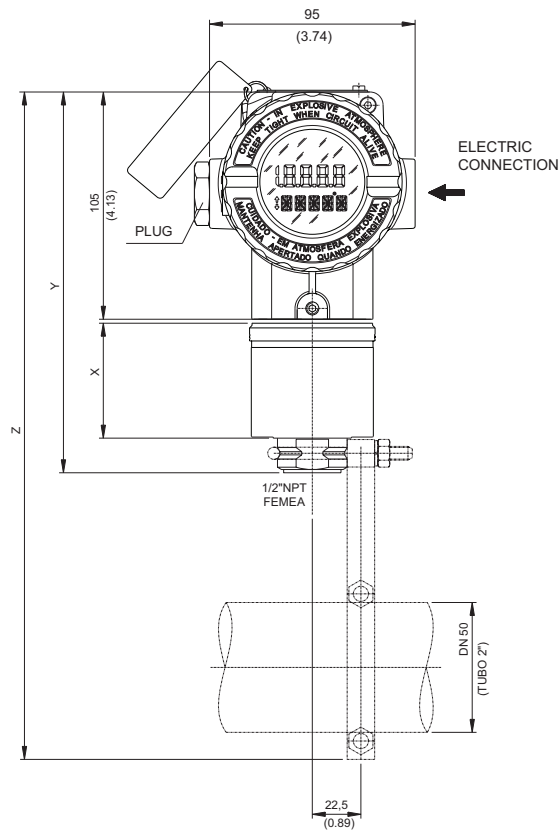

LD400G - Gage Inline Pressure Transmitter Wireless

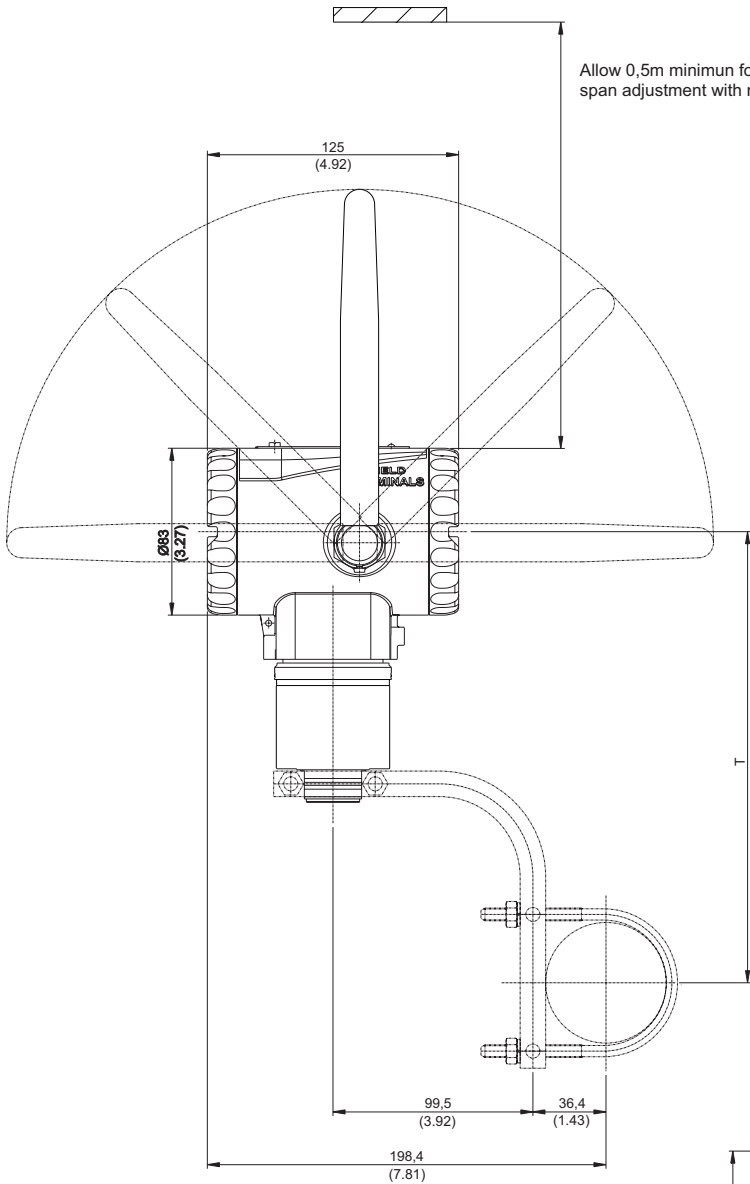

RANGE	DIMENSIONS mm (")			
	X	Y	T	Z
2-3	48,6 (1.91)	171,5 (6.75)	219,5 (8.64)	303,5 (11.95)
4	50,6 (1.99)	173,5 (6.83)	221,5 (8.72)	305,5 (12.03)
5	53,1 (2.09)	176 (6.93)	224 (8.82)	308 (12.13)

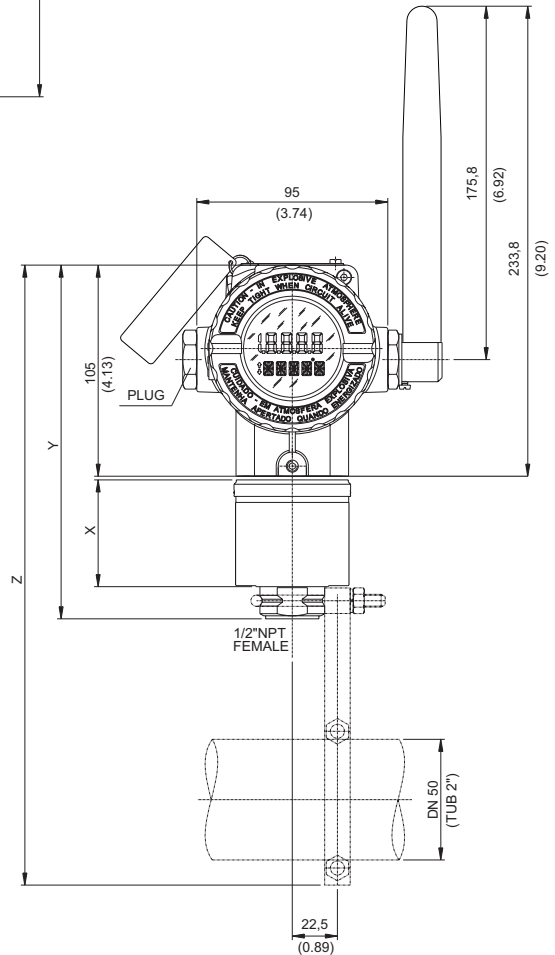
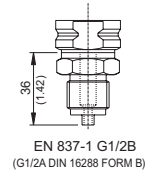
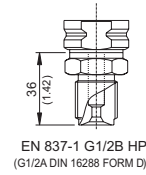
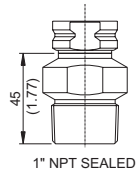
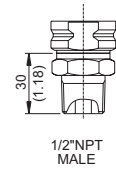

LD400I - Pressure Transmitter with Extended Probe

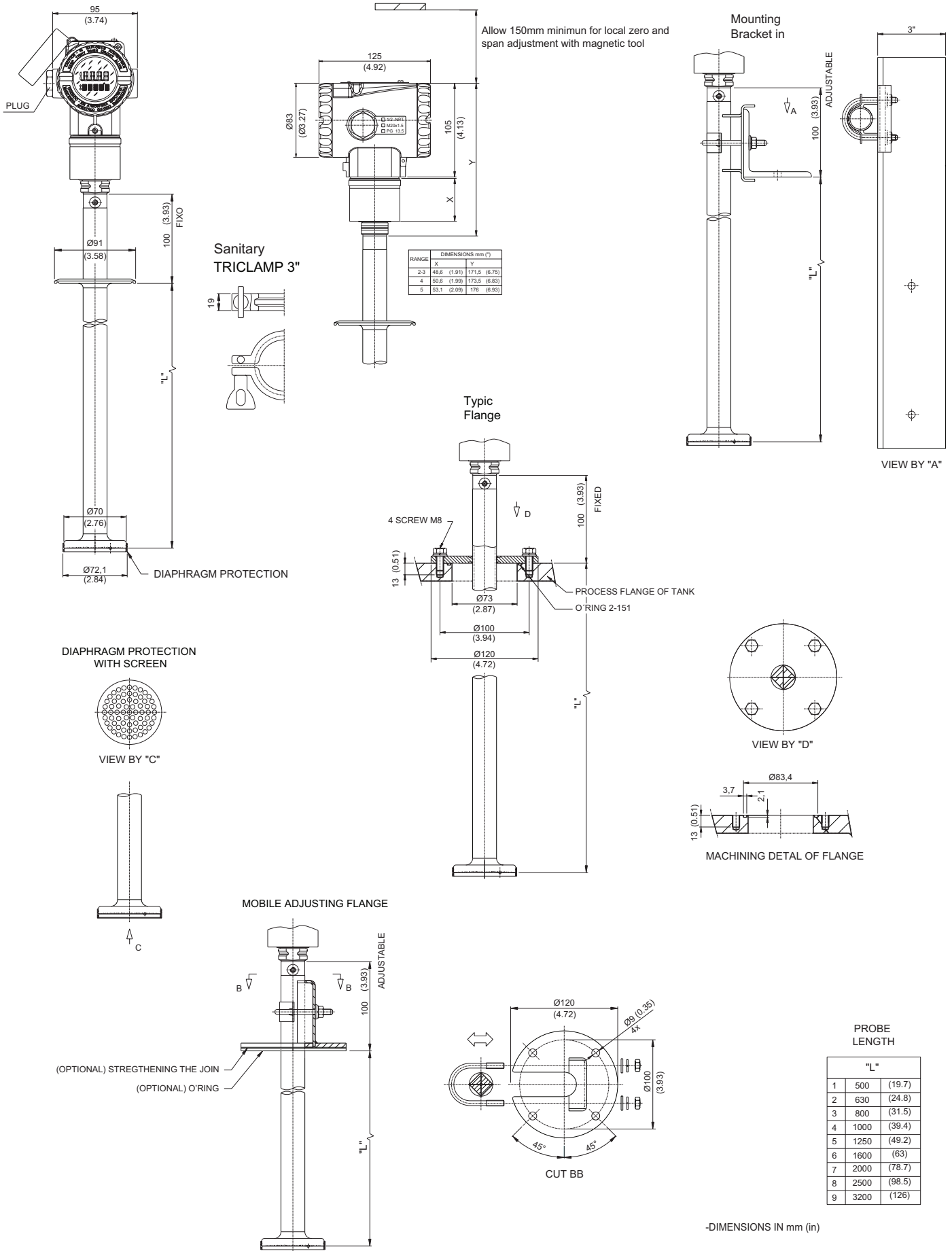

Dimensional Drawing

LD400I - Pressure Transmitter with Extended Probe Wireless

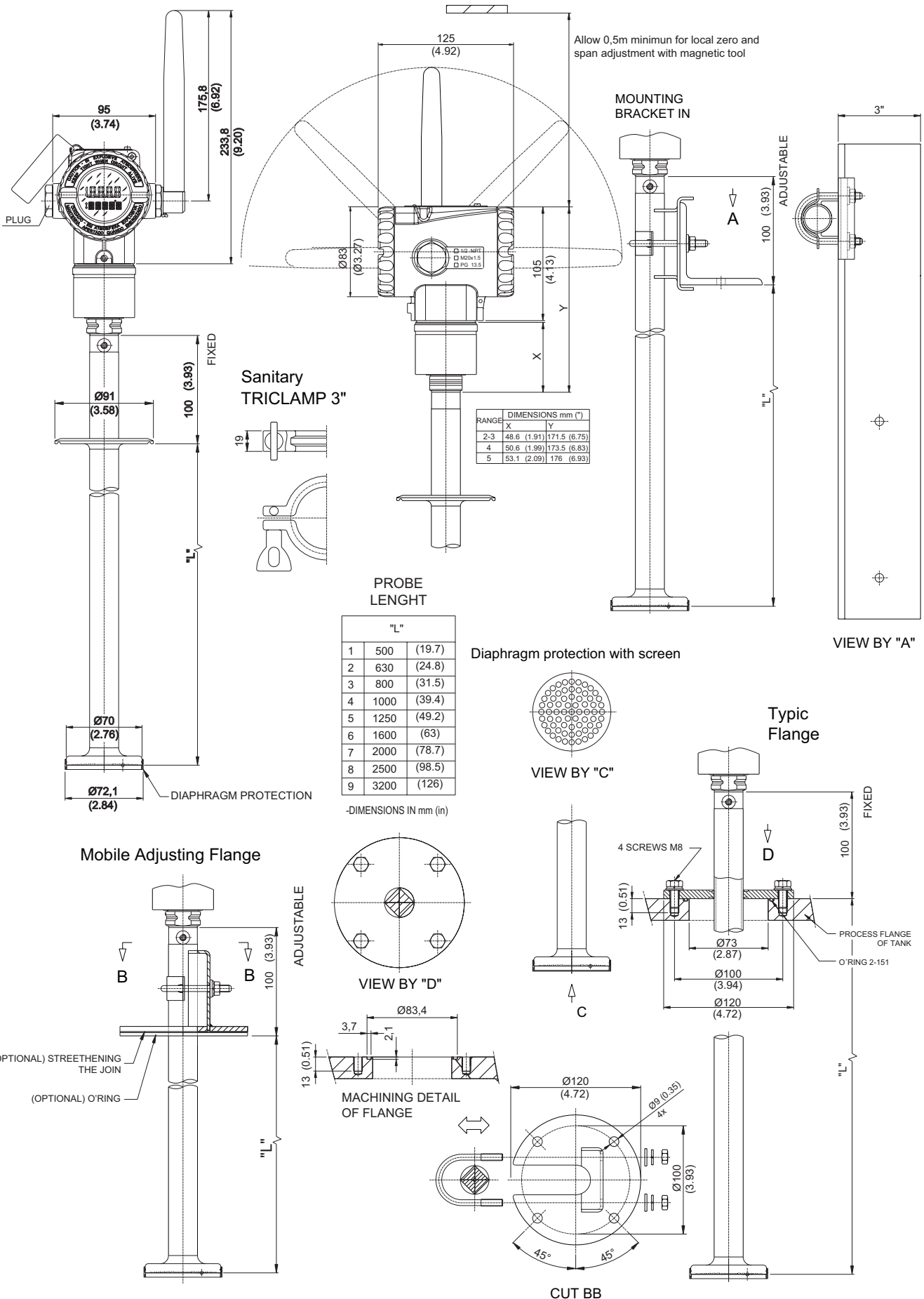

smar
www.smar.com

Specifications and information are subject to change without notice.
Up-to-date address information is available on our website.

web: www.smar.com/contactus.asp

